

SCG3040 Synchronous Clock Generator

PLL

2111 Comprehensive Drive
Aurora, Illinois 60505
Phone: 630-851-4722
Fax: 630-851-5040
www.conwin.com

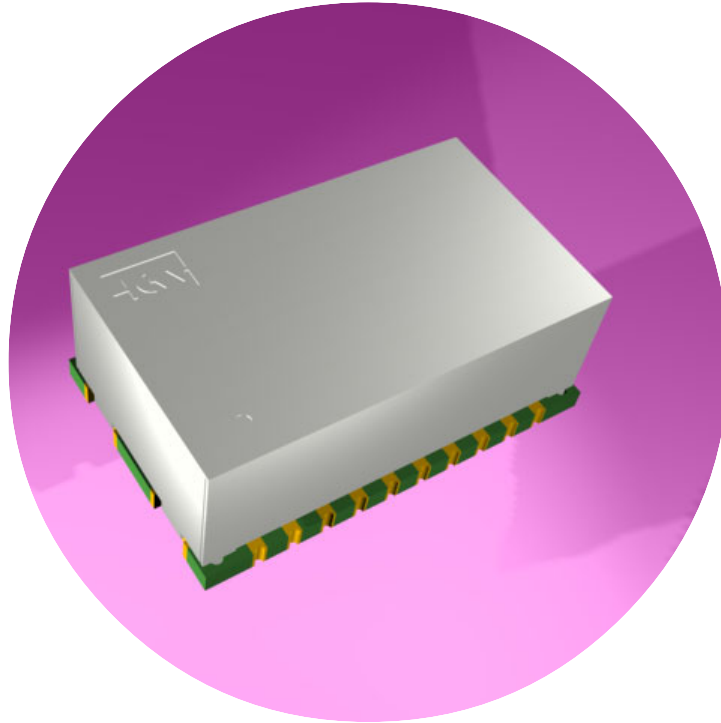

Application

The SCG3040 is designed for use as a reference input for OC-48 Framers and SERDES. It generates less than 1 psRMS jitter over the OC-48 bandwidth.

SCG3040 is well suited for use in line cards, service termination cards and similar functions to provide reliable reference, phase locked, synchronization for TDM, PDH, SONET, and SDH network equipment. The SCG3040 provides a jitter filtered, wander following output signal synchronized to a superior Stratum or peer input reference signal.

Features

- 3.3V High Precision PLL
- Two Differential LVPECL Outputs. 155.52 MHz or 77.76 MHz
- 19.44 MHz CMOS Input Reference
- Reference Duty Cycle Tolerant
- Low Temperature Reflow Surface Mounting

Bulletin	SG033
Page	1 of 12
Revision	P02
Date	22 NOV 04
Issued By	MBatts

General Description

The SCG3040 is a mixed signal phase locked loop generating 77.76 MHz or 155.52 MHz Dual LVPECL outputs from an intrinsically low jitter voltage controlled crystal oscillator. The SCG3040 is phase locked to an external 19.44 MHz reference input. The SCG3040 is ideal for applications using multiplication to obtain

higher SONET frequencies.

The package dimensions are 0.75" x 1.25" x .45" on a 6 layer, designed impedance, FR4 board with castellated pins. Parts are assembled using high temperature solder to withstand surface mount reflow processes. See Fig. 4 for the solder profile.

Functional Block Diagram

Figure 1

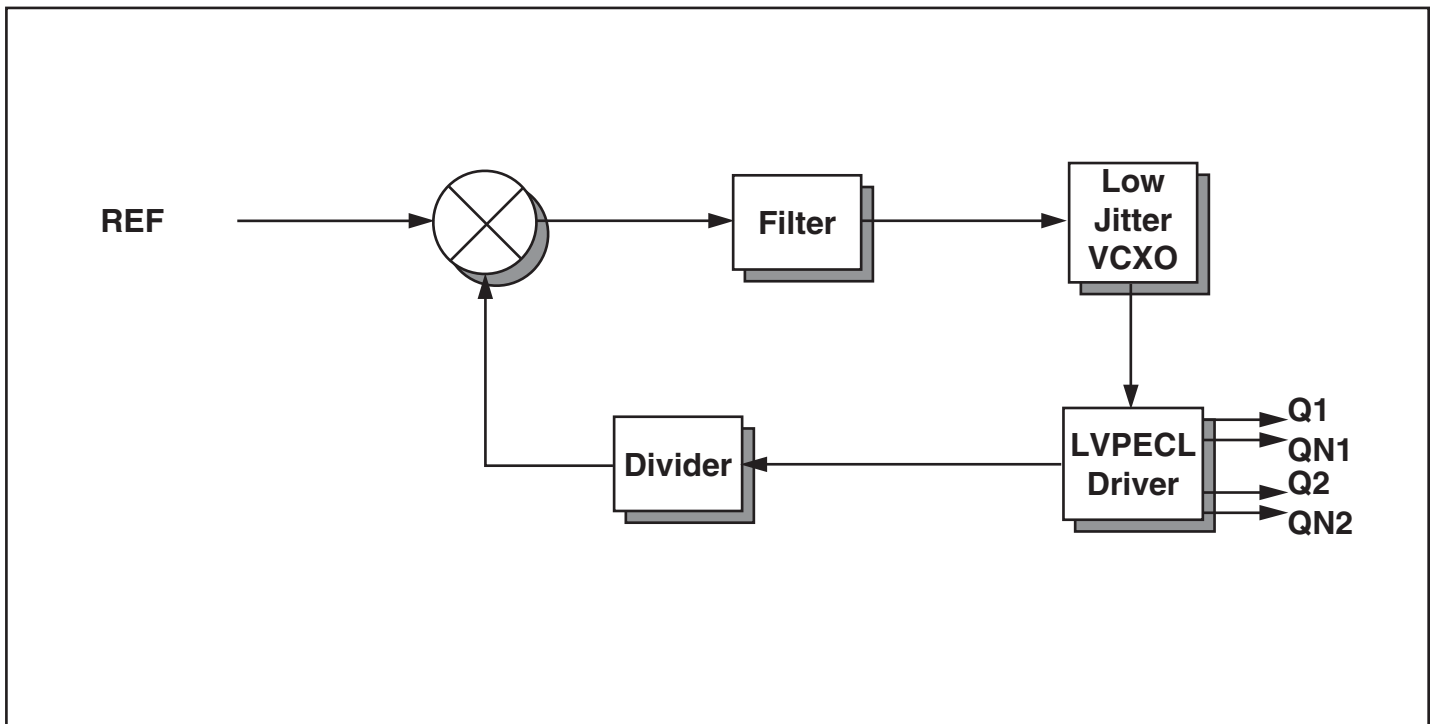

Absolute Maximum Rating

Table 1

Symbol	Parameter	Minimum	Nominal	Maximum	Units	Notes
V_{CC}	Power Supply Voltage	-0.5		4	Volts	1
V_I	Input Voltage	-0.5		5.5	Volts	1
T_s	Storage Temperature	-65		150	deg. C	1

Recommended Operating Specifications

Table 2

Symbol	Parameter	Minimum	Nominal	Maximum	Units	Notes
V _{CC}	Power Supply Voltage	3.135	3.3	3.465	Volts	2, 9
I _{CC}	Power Supply Current	-	-	270	mA	5, 6
T _{OP}	Temperature Range	0	-	70	deg. C	
F _O	Available Output Frequencies Q1,Q2	77.76	-	155.52	MHz	
F _{REF}	Reference Frequency	-	19.44	-	MHz	
F _{CAP}	Capture/Pull-in Range	-25	-	25	ppm	
F _{BW}	Jitter Filter Bandwidth	-	8	15	Hz	3
T _{JTOL}	Input Jitter Tolerance <i>(Input Jitter Frequencies ≥ 10 Hz)</i>	-	-	31.25	us	
T _{AQ}	Acquisition Time	-	100	-	ms	4
J _{GEN}	Jitter Generation Q1,Q2	-	-	1	ps RMS	7

Input And Output Characteristics

Table 3

Symbol	Parameter	Minimum	Nominal	Maximum	Units	Notes
CMOS Input Characteristics						
V _{IH}	High Level Input Voltage	2	-	5.5	V	
V _{IL}	Low Level Input Voltage	0	-	0.8	V	
T _{IR}	Input Reference Pulse Width	12.5	-	-	nS	
T _{IRF}	Input Rise and Fall Time (20% to 80%)	-	-	5	nS	8
LVPECL Output Characteristics						
V _{OH}	High Level Output Voltage	2.27	2.34	2.52	V	5
V _{OL}	Low Level Output Voltage	1.49	1.51	1.68	V	5
C _L	Output Capacitance	-	-	10	pF	
T _{SKEW}	Differential Output Skew	-	50	-	ps	5
T _{RF}	Output Rise and Fall Time (20% to 80%)	-	-	1	ns	5
DC	Duty Cycle	45	50	55	%	5

NOTES: 1: Operation of the device at these or any other condition beyond those listed under Recommended Operating Specifications is not implied. Exposure to Absolute Maximum Rating conditions for extended periods of time may affect device reliability.
 2: Requires external regulation and supply decoupling. (22uF, 330 pF)
 3: 3dB loop response.
 4: From a 20 ppm step in reference frequency.

5: With LVPECL termination as defined by figure 8 (Z_o = 50 Ω).
 6: Maximum I_{CC} tested at V_{CC} = 3.46V
 7: Jitter based on SONET OC-48 bandwidth (12 kHz - 20 MHz).
 8: Avoid meta-stable input signals
 9: Vcc ramp rate must be monotonic rising. Ramp must be greater than 300 V/s from 2V to 3V.

Pin Description

Table 4

Pin #	Connection	Description
1	N/C	Do Not Connect or Route Through
2	REF	CMOS Input Reference
3	TDO	JTAG pin that is used only by Connor-Winfield for programming. Do not connect
4	GND	Ground
5	QN1	Negative LVPECL Differential Output
6	Q1	Positive LVPECL Differential Output
7	V _{cc}	Supply Voltage Relative to Ground
8	GND	Ground
9	N/C	Do Not Connect or Route Through
10	N/C	Do Not Connect or Route Through
11	Q2	Positive LVPECL Differential Output
12	QN2	Negative LVPECL Differential Output
13	GND	Ground
14	GND	Ground
15	V _{cc}	Supply Voltage Relative to Ground
16	TDI	JTAG pin that is used only by Connor-Winfield for programming. Do not connect
17	TCK	JTAG pin that is used only by Connor-Winfield for programming. Do not connect
18	TMS	JTAG pin that is used only by Connor-Winfield for programming. Do not connect
19	GND	Ground
20	N/C	Do Not Connect or Route Through

Package Dimensions

Figure 2

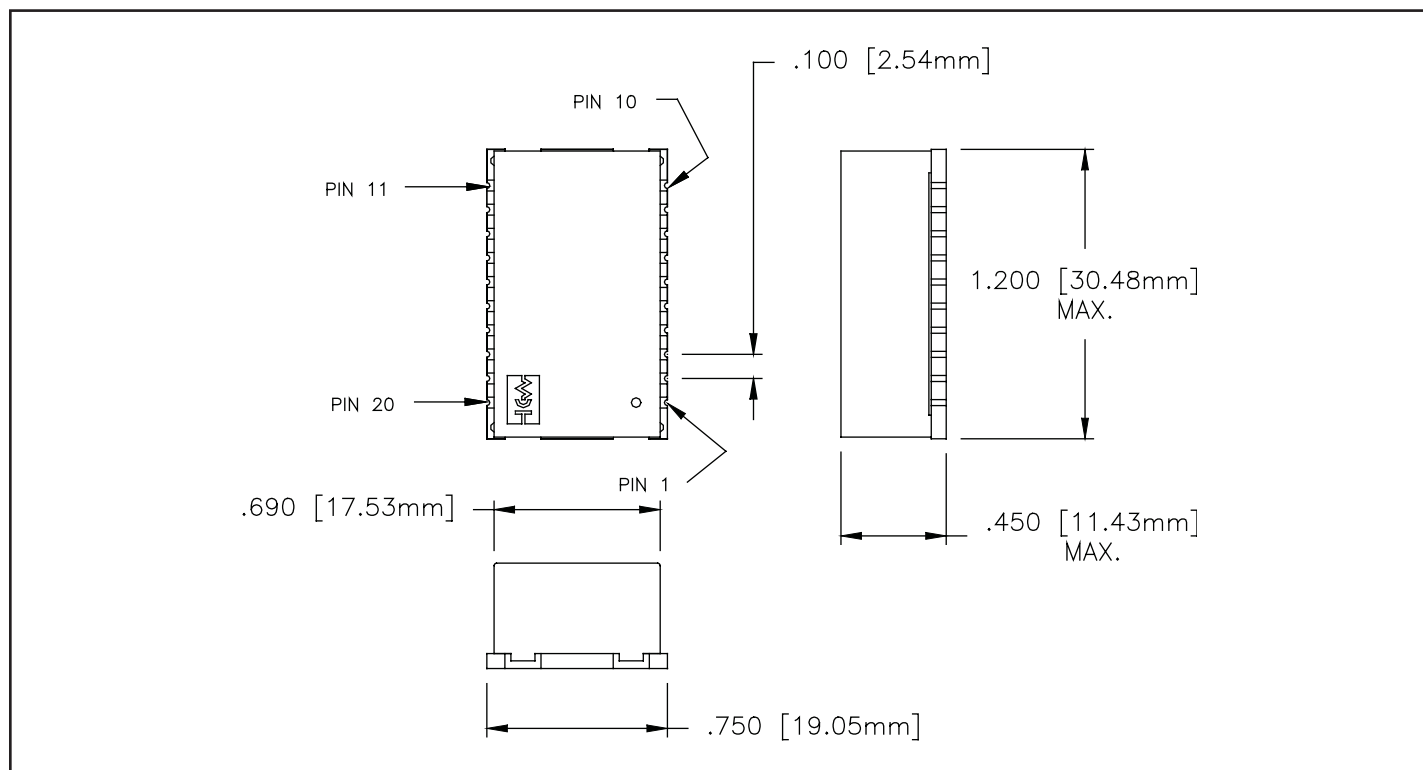

Recommended Footprint Dimensions

Figure 3

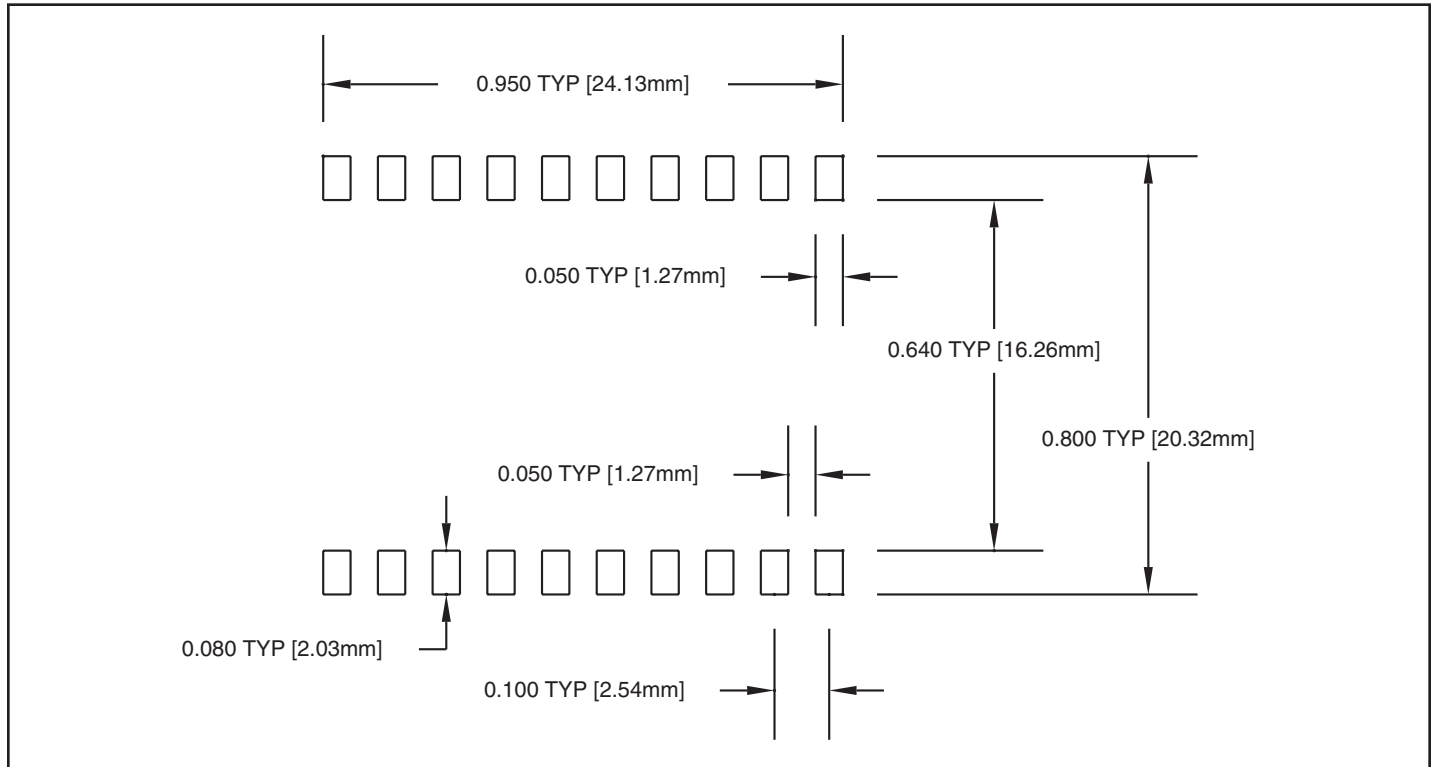

Solder Profile

Figure 4

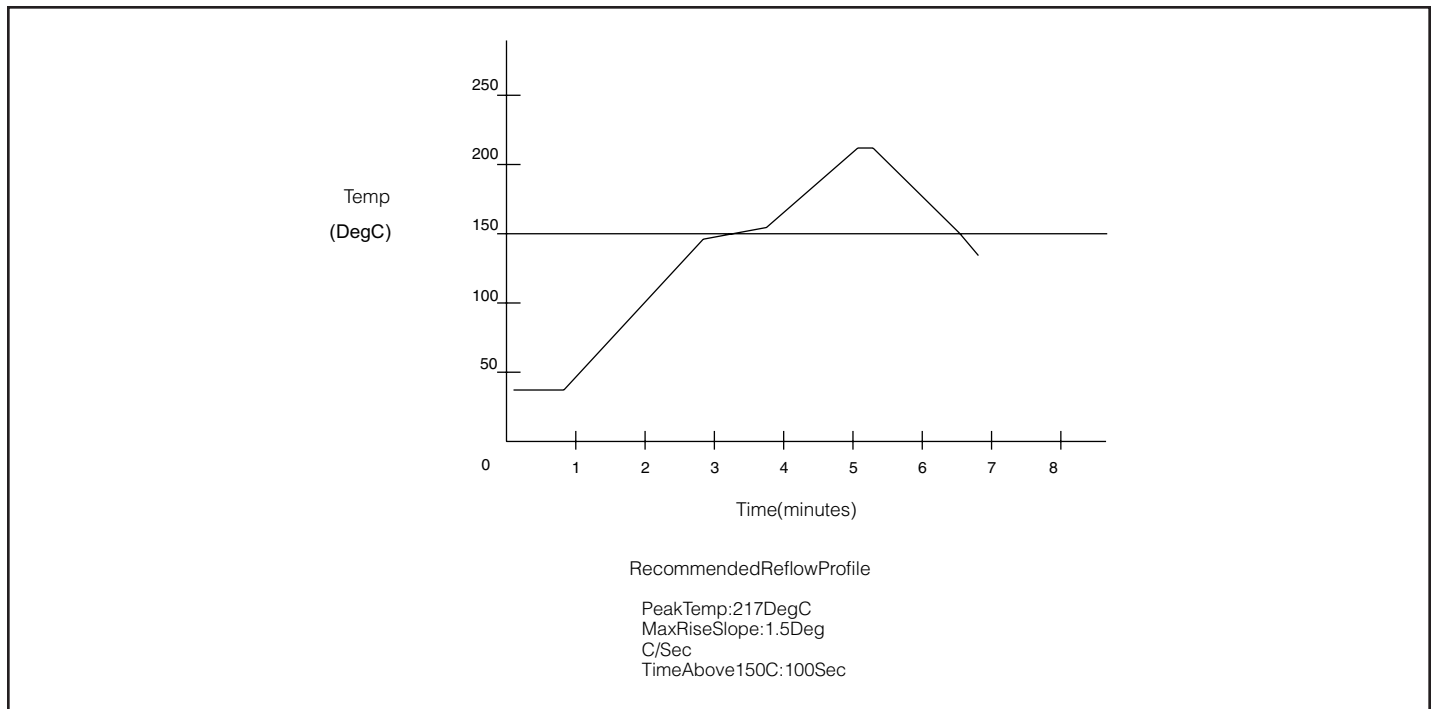

Tape and Reel Dimensions

Figure 5

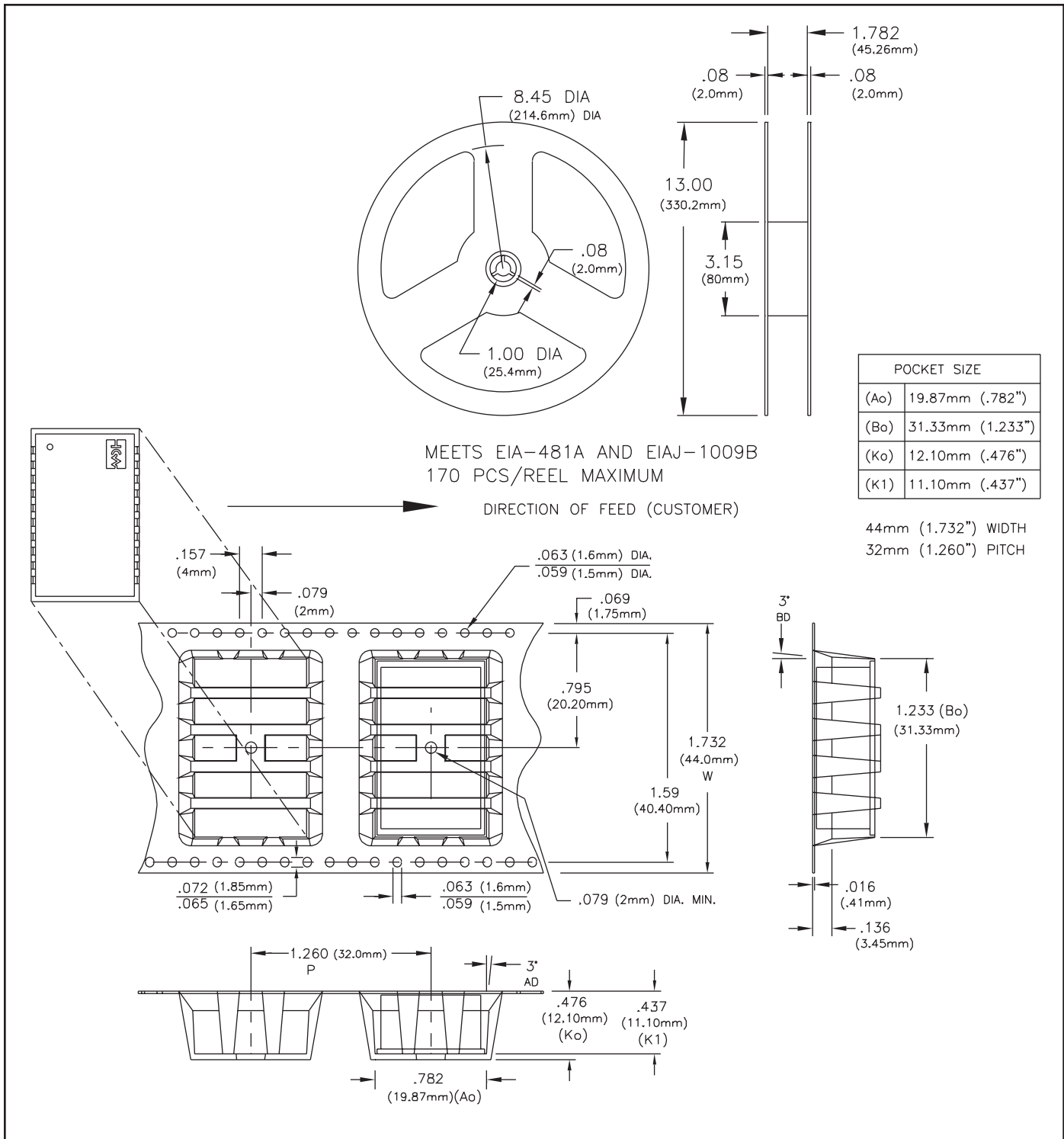

Recommended Keepout Area & Customer PCB Stackup

Figure 6

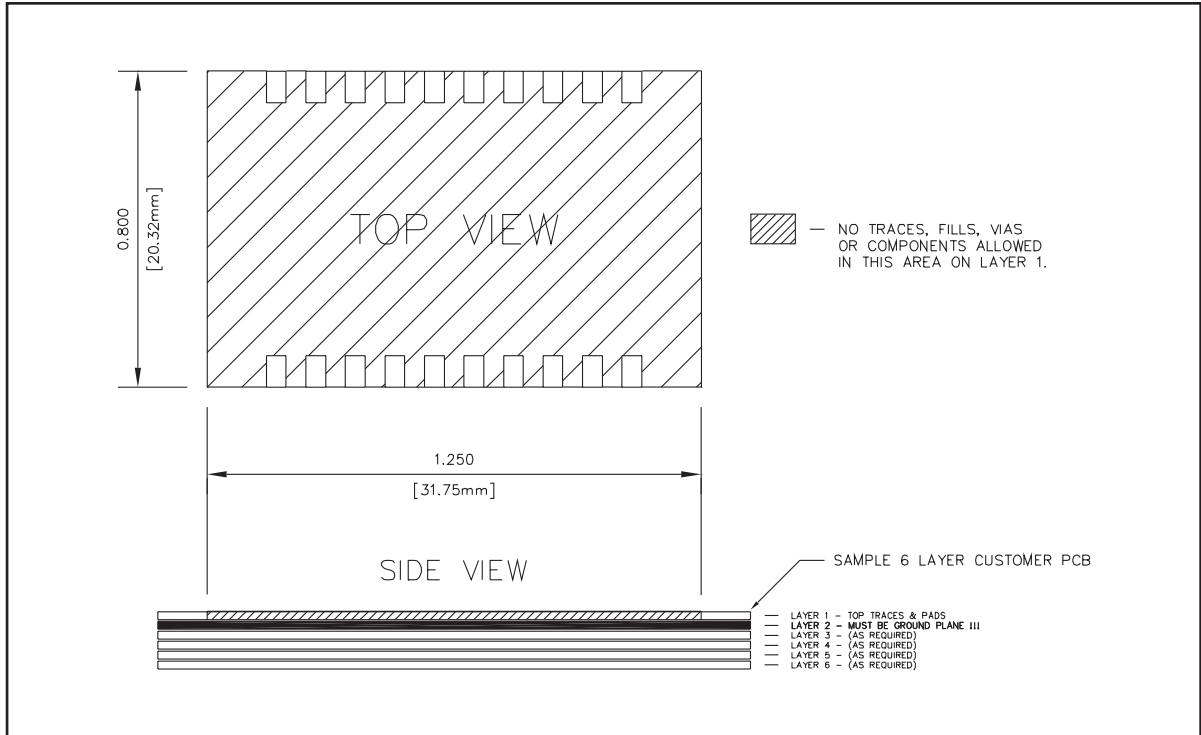

Jitter Attenuation vs. Input Jitter Frequency

Figure 7

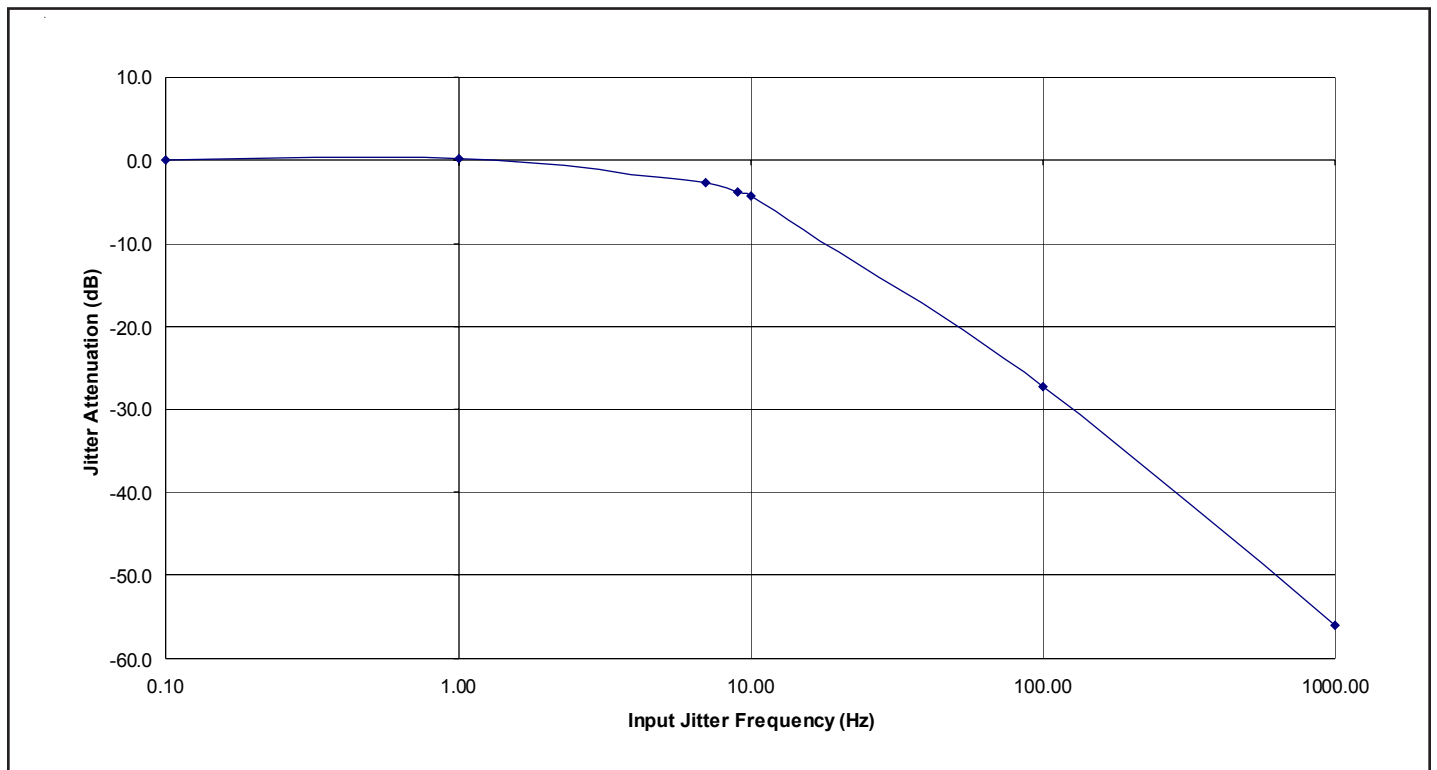

Recommended LVPECL Termination

Figure 8

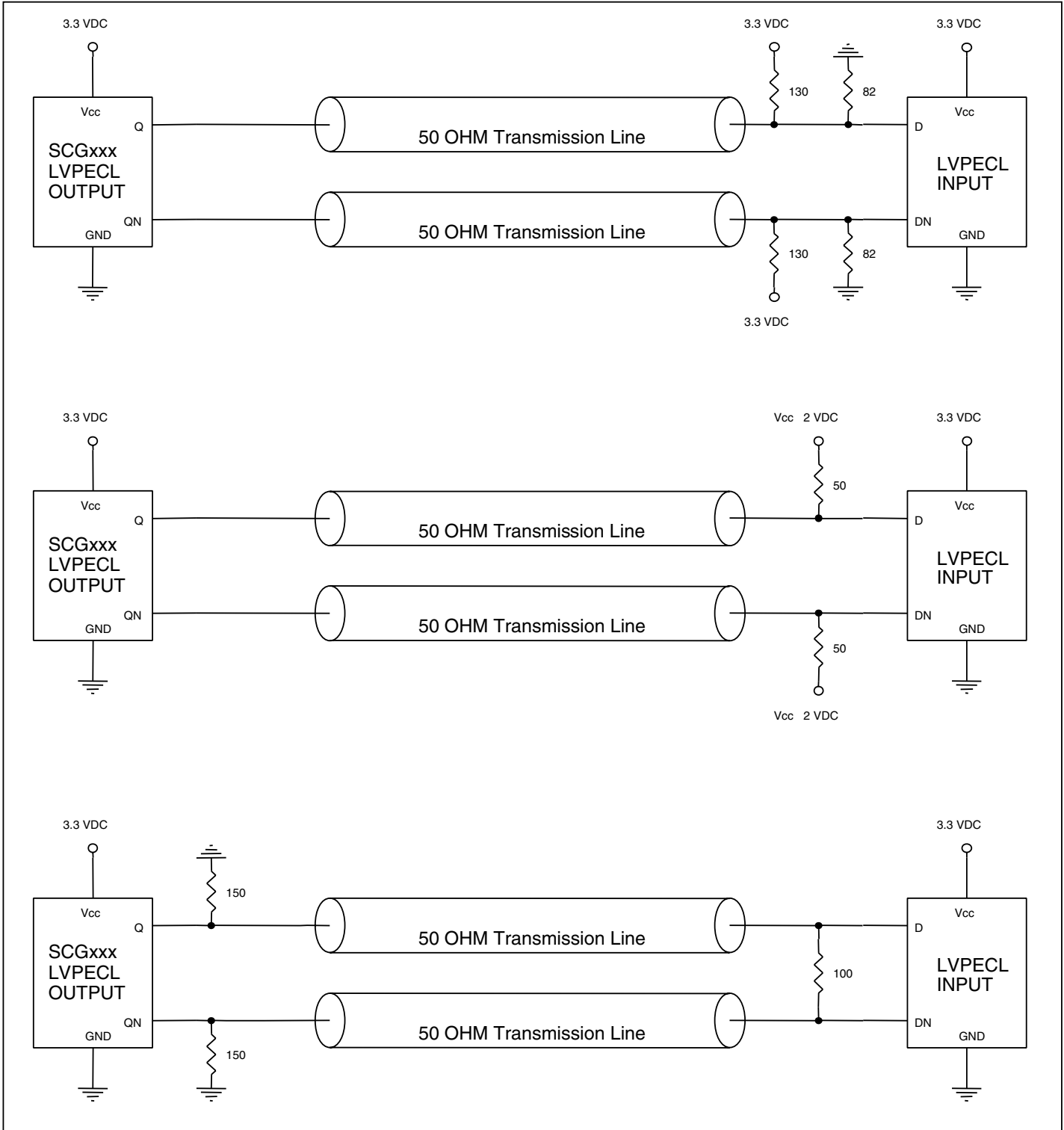

NOTES: 8: Q & QN are differential open emitter outputs

Typical Phase Noise Plot

Figure 9

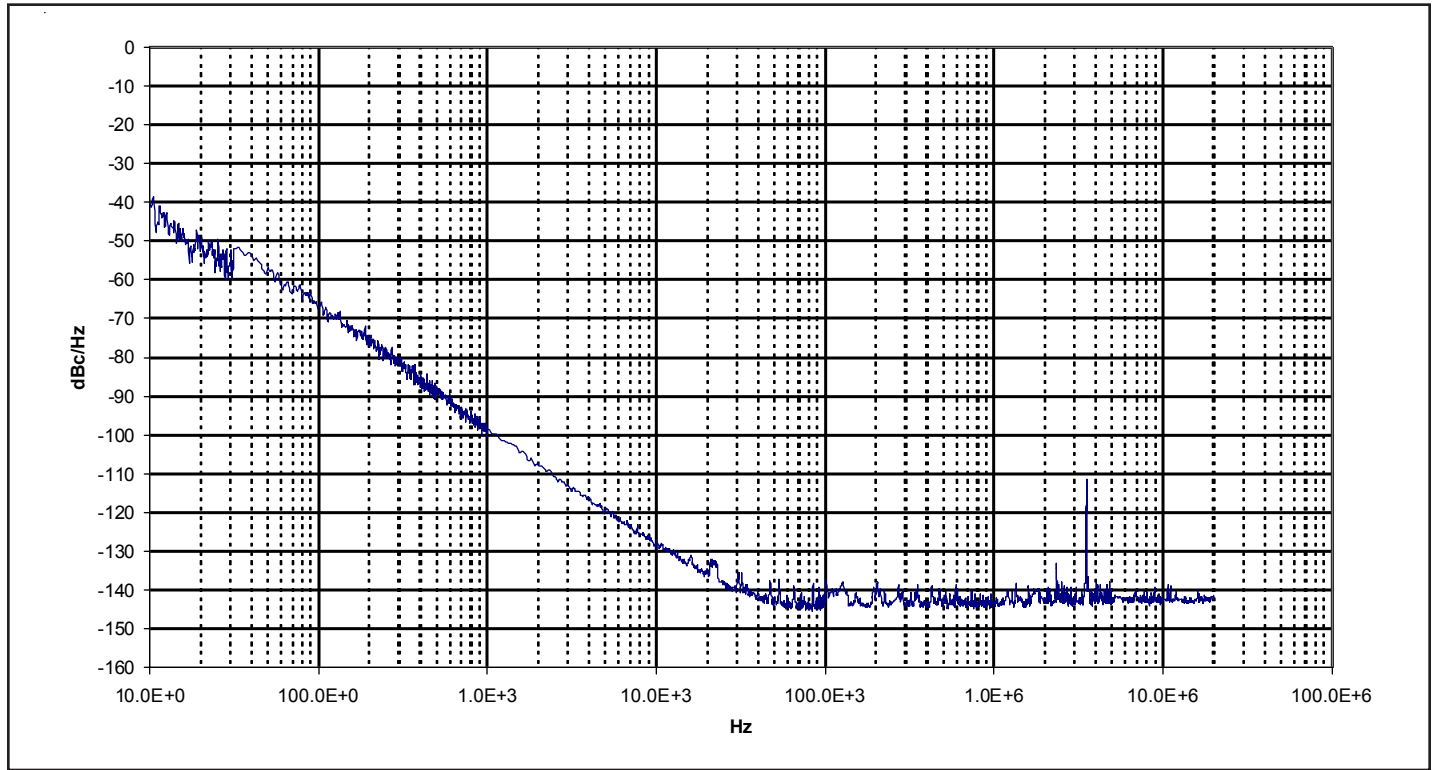

Typical TDEV Plot

Figure 10

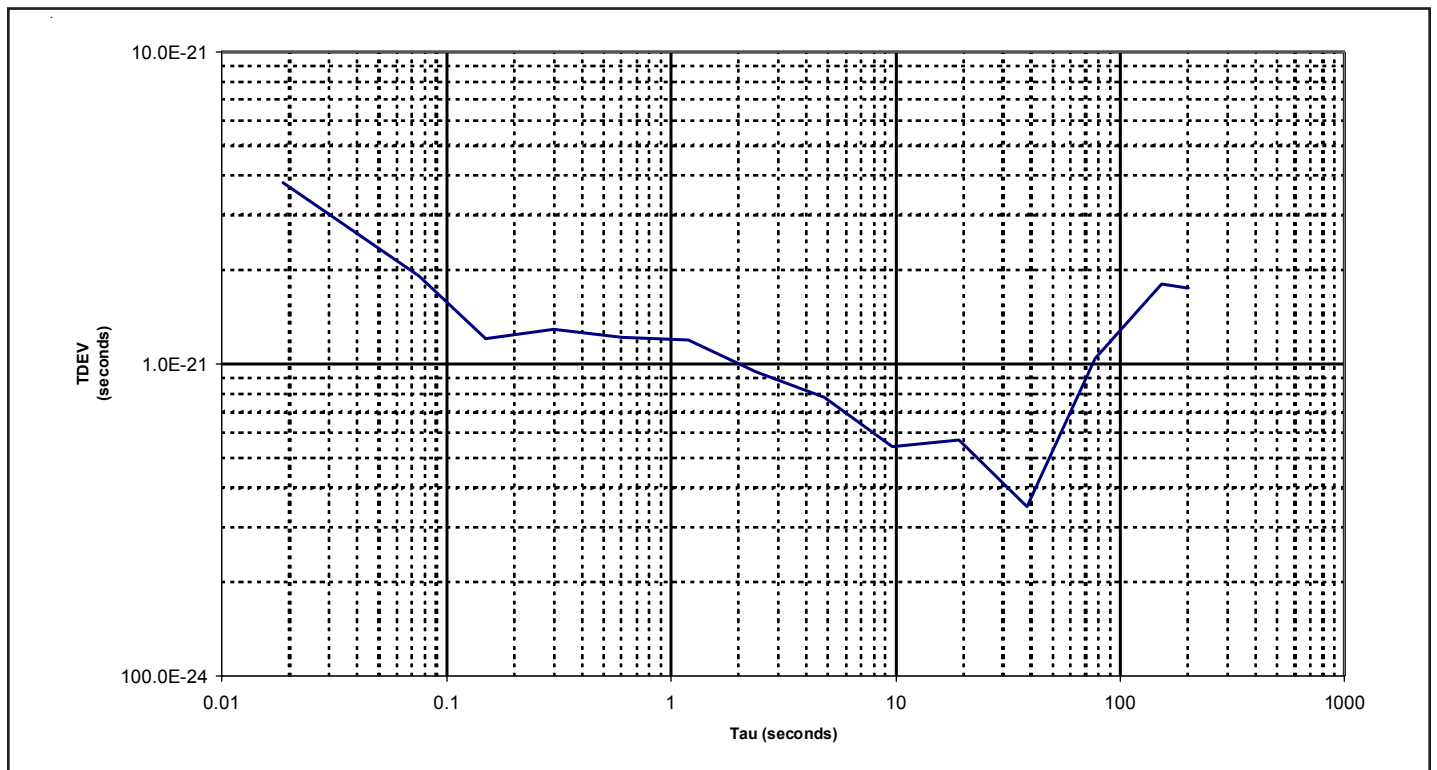

Typical MTIE Plot

Figure 11

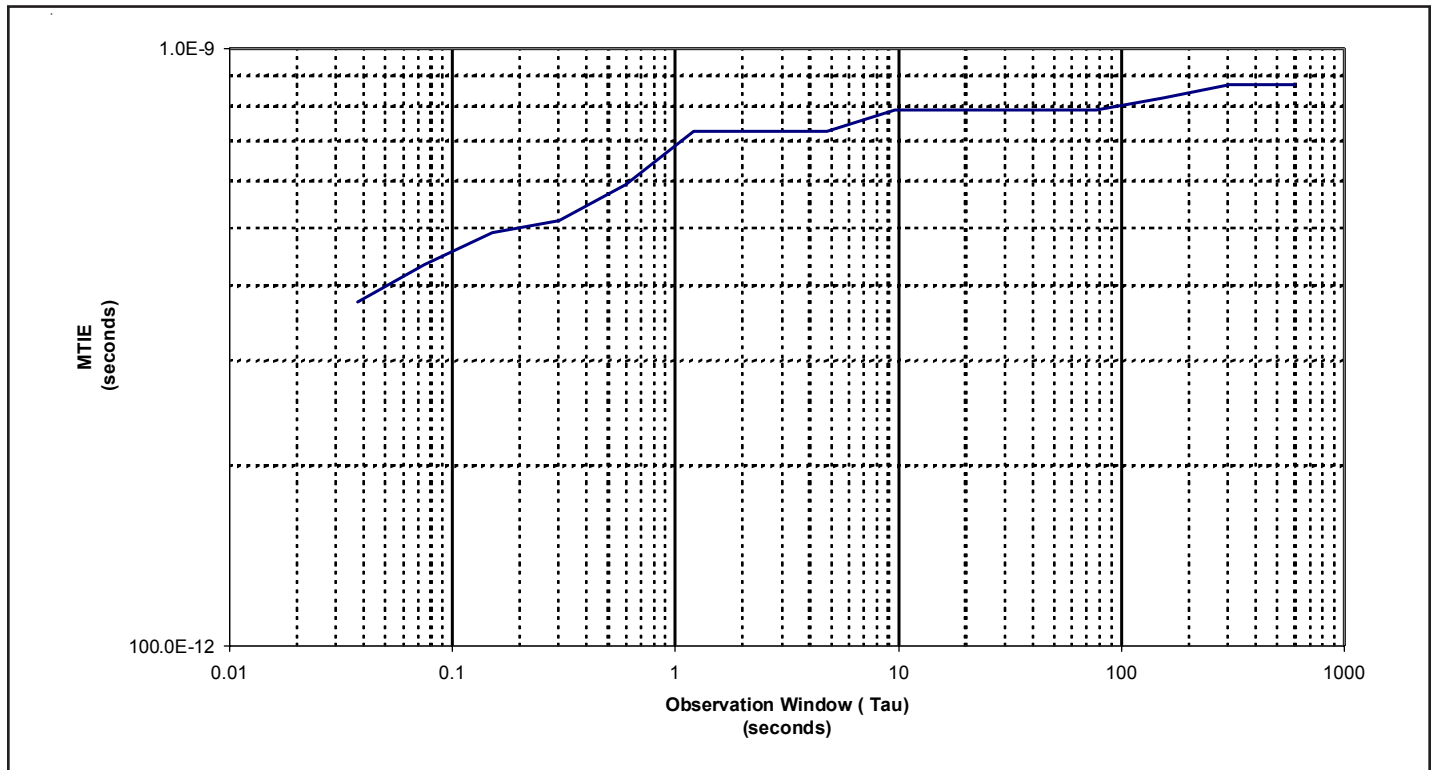

Typical Step Response due to a 20ppm Frequency Step

Figure 12

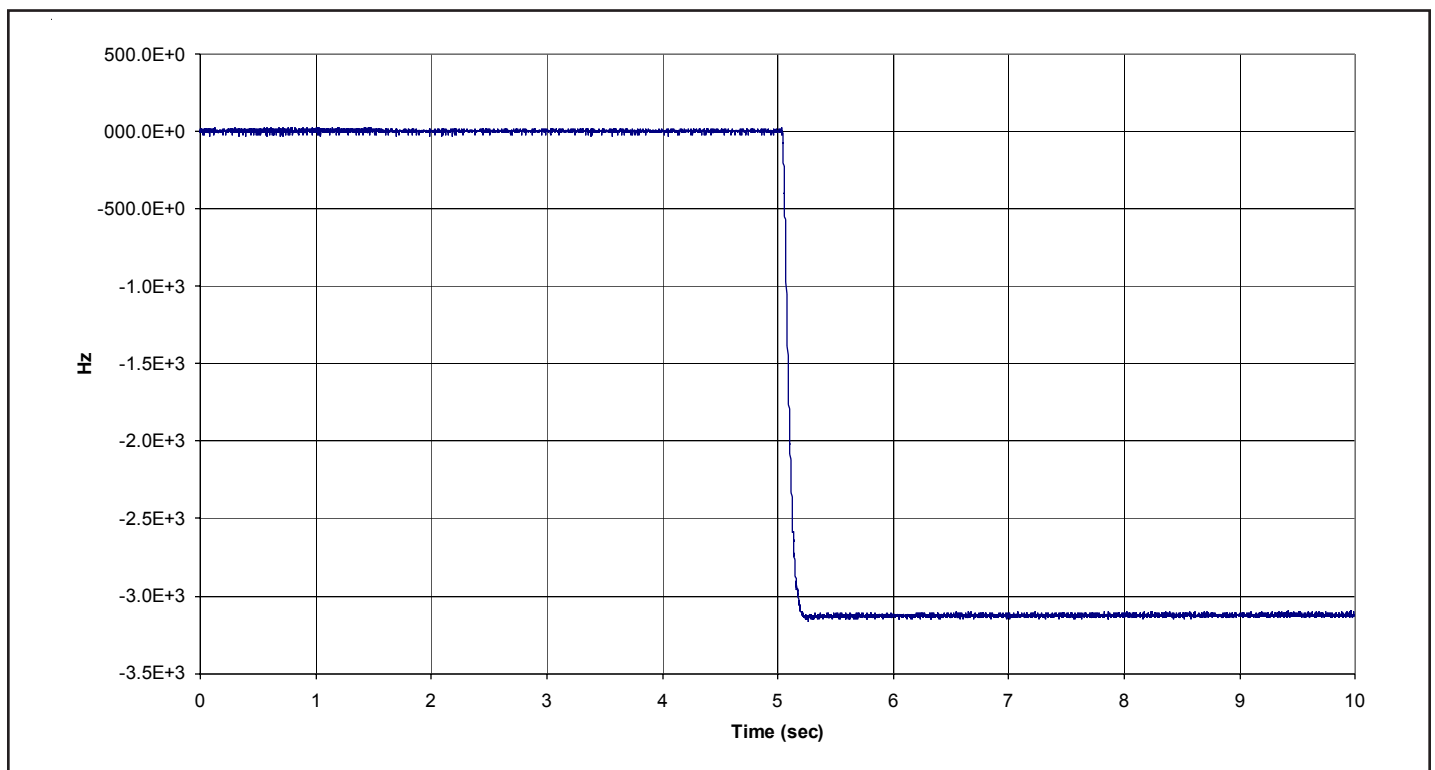

Ordering Information

SCG{XXXX}-{FFF.FFF}{M}

XXXX equals a specific model (3040)

FFF.FFF equals the Oscillator Output frequency (077.76, 155.52)

M equals MHZ and is added to all part numbers

Example: To order an SCG3040 with a dual LVPECL Output of 155.52 MHz,
Order part number SCG3040-155.52M

Please contact Connor-Winfield for other frequencies that may be available.

Revision	Revision Date	Note
P00	2/5/02	Preliminary Informational Release
P01	11/22/02	Revised Mechanical Drawing
P02	11/22/04	Added new frequency, 77.76 MHz

**CONNOR
WINFIELD**



2111 Comprehensive Drive
Aurora, Illinois 60505
Phone: 630-851-4722
Fax: 630-851-5040
www.conwin.com