

SCG4001 Synchronous Clock Generators

PLL

2111 Comprehensive Drive
Aurora, Illinois 60505
Phone: 630-851-4722
Fax: 630-851-5040
www.conwin.com

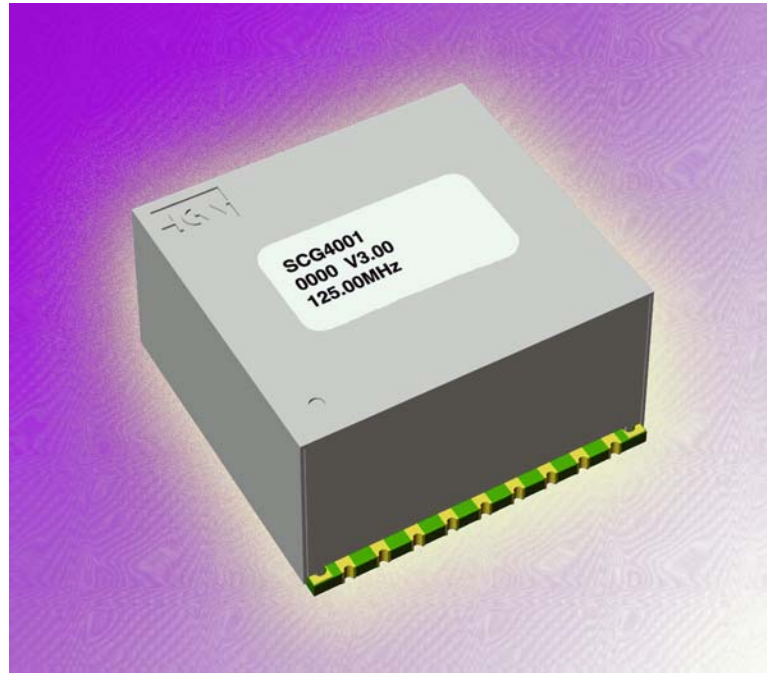

Application

The Connor-Winfield SCG4001 provides high precision phase lock loop frequency translation for the telecommunication applications.

SCG4001 is well suited for use in line cards, service termination cards and similar functions to provide reliable reference, phase locked, synchronization for TDM, PDH, SONET and SDH network equipment. The SCG4001 provides a jitter filtered, wander following output signal synchronized to a superior Stratum or peer input reference signal.

The SCG4001 is designed to operate with a STRATUM 4 reference

Features

- ± 32 ppm Absolute Pull-in Range
- 3.3V High Precision PLL
- Tri-State Capability
- Active Alarms
- Guaranteed Free Run ± 20 ppm
- 1 sec. Acquisition Time

Bulletin	SG043
Page	1 of 12
Revision	P00
Date	08 AUG 02
Issued By	MBatts

General Description

The SCG4001 is a digital phase locked loop generating a LVPECL outputs from an intrinsically low jitter voltage controlled crystal oscillator. The LVPECL outputs may be disabled. The jitter attenuated internal reference, divided down from the output frequency, is also output to a pin.

The SCG4001 can only lock to an 8kHz reference. A filtered reference output signal is available at the same frequency. The unit has an acquisition time of about 1 second and it is tolerant of different reference duty cycles.

Further features include alarm outputs for Loss-of-Reference (LOR) and Loss-of-Lock (LOL). During the LOR alarm, the SCG4000 will also enter a Free Run state,

which will guarantee a 20 ppm accurate output. Additionally the Free Run mode may be entered manually.

The alarms and reference output may be put into the tri-state high impedance condition for external testing purposes.

The package dimensions are 1.025" x 1.0" x 0.429" on a 6 layer FR4 board with castellated pins. Parts are assembled using high temperature solder to withstand 63/37 alloy, 180° C surface mount reflow processes.

Functional Block Diagram

Figure 1

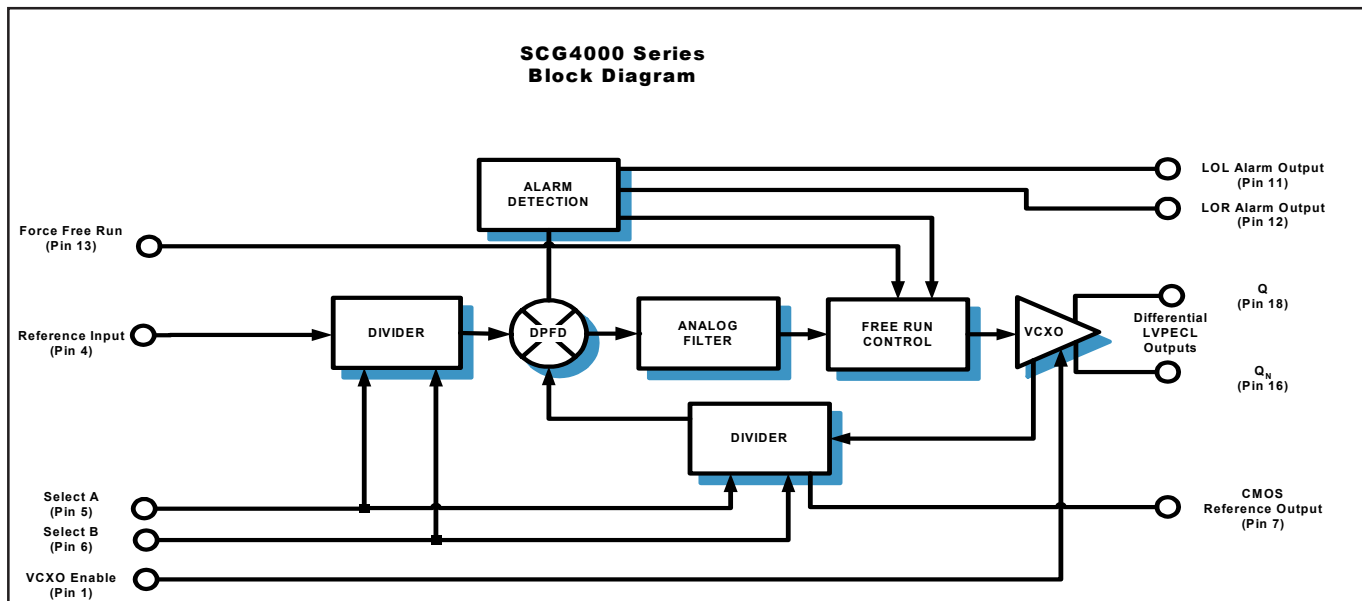

Absolute Maximum Rating

Table 1

Symbol	Parameter	Minimum	Nominal	Maximum	Units	Notes
Vcc	Power Supply Voltage	3.0		3.6	Volts	
V1	Input Voltage	-0.5		5.5	Volts	
Ts	Storage Temperature	-65		150	deg. C	

Operating Specifications

Table 2

Symbol	Parameter	Minimum	Nominal	Maximum	Units	Notes
V_{cc}	Power Supply Voltage	3.135	3.3	3.465	Volts	1.0
I_{cc}	Power Supply Current	-	230	280	mA	
T_o	Temperature Range	0	-	70	°C	
F_{fr}	Free Run Accuracy	-20	-	20	ppm	
F_{cap}	Capture/pull-in range	-32	-	32	ppm	
F_{bw}	Jitter Filter Bandwidth	-	-	10	Hz	
T_{jtol}	Input Jitter Tolerance	-	-	6.25	µs	
T_{aq}	Acquisition Time	-	1	-	s	2.0
T_{rf}	Output Rise and Fall Time (20% 80%)	100	225	350	ps	3.0

Features

Table 3

Parameter	Specifications	Notes
Alarms	LOR, LOL Status on separate CMOS Outputs	
TDEV	70 ps (typical)	
MTIE	800 ps (typical)	
VCXO Output Logic Type	LVPECL	
Reference Output Logic Type	CMOS	
Package	FR4 SM 1.025" x 1.0" x 0.429"	

CMOS Input And Output Characteristics

Table 4

Symbol	Parameter	Minimum	Nominal	Maximum	Units	Notes
V_{IH}	High Level Input Voltage	2		5.5	V	
V_{IL}	Low Level Input Voltage	0		0.8	V	
T_{IO}	I/O to Output Valid			10	nS	
C_o	Output Capacitance			10	pF	
V_{HO}	High Level Output Voltage $I_{oh} = 04mA$	2.4				V_{cc} Min.
V_{IO}	Low Level Output Voltage $I_{o1} = 8mA$			0.4		V_{cc} Max.
T_{IR}	Input Reference Signal Pulse Width	12.5			nS	

NOTES: 1.0: Requires external regulation and filter (22µF, 330 pF)
 2.0: From a 20 ppm offset in reference frequency
 3.0: 50Ω load biased to 1.3V

LVPECL Output Characteristics

Table 5

Symbol	Parameter	Minimum	Nominal	Maximum	Units	Notes
V _{OH}	High Level PECL Voltage	2.27	2.34	2.42	V	
V _{OL}	Low Level PECL Voltage	1.49	1.51	1.68	V	
C _L	Output Capacitance			10	pF	
T _{SKEW}	Differential Output Skew		50		ps	

Output Jitter Specifications

Table 6

Jitter BW 10 Hz - 1 MHz			SONET Jitter BW 12 kHz - 20 MHz	
Frequency (MHz)	pS (RMS)	m UI	pS (RMS)	m UI
125.0	20(typical)	2.5 (typical)	1 (max), 0.3 (typical)	0.125(max)

Output Programming

Table 7

Tristate	Free Run	Output
0	0	Locked to reference selected (default)
1	X	Hi-Z Tristate condition
0	1	Free run at nominal frequency

Alarm Status

Table 9

LOL Output	LOR Output	Alarm Output
0	0	No alarm
1	0	Loss-of-Lock
X	1	Loss-of-Reference

Pin Description

Table 8

Pin #	Connection	Description
1	Enable/Disable	Enable = 0, Disable = 1 for VCXO Outputs, Default = 0 (for No Connect)
2	TCK	JTAG pin that is used only by Connor-Winfield for programming. Do not connect
3	TDO	JTAG pin that is used only by Connor-Winfield for programming. Do not connect
4	Reference In	CMOS Reference Frequency Input
5	Select A	Reference Frequency Select Pin, Default = 0 (for No Connect)
6	Select B	Reference Frequency Select Pin, Default = 0 (for No Connect)
7	Reference Out	Filtered Reference Output
8	Ground	Power Ground
9	Tri-State Enable	CMOS Output Tri-State enable (Hi-Z =1, Default = 0)
10	V _{CC}	3.3V Supply Voltage.
11	Loss of Lock	LOL Alarm Output
12	Loss of Reference	LOR Alarm Output
13	Free Run	Force output frequency to Free Run (FR = 1, Default = 0)
14	TDI	JTAG pin that is used only by Connor-Winfield for programming. Do not connect
15	TMS	JTAG pin that is used only by Connor-Winfield for programming. Do not connect
16	VCXO Out	VCXO differential LVPECL Output
17	Signal Ground	VCXO output ground (Shield)
18	VCXO Out	VCXO differential LVPECL Output

Package Dimensions

Figure 2

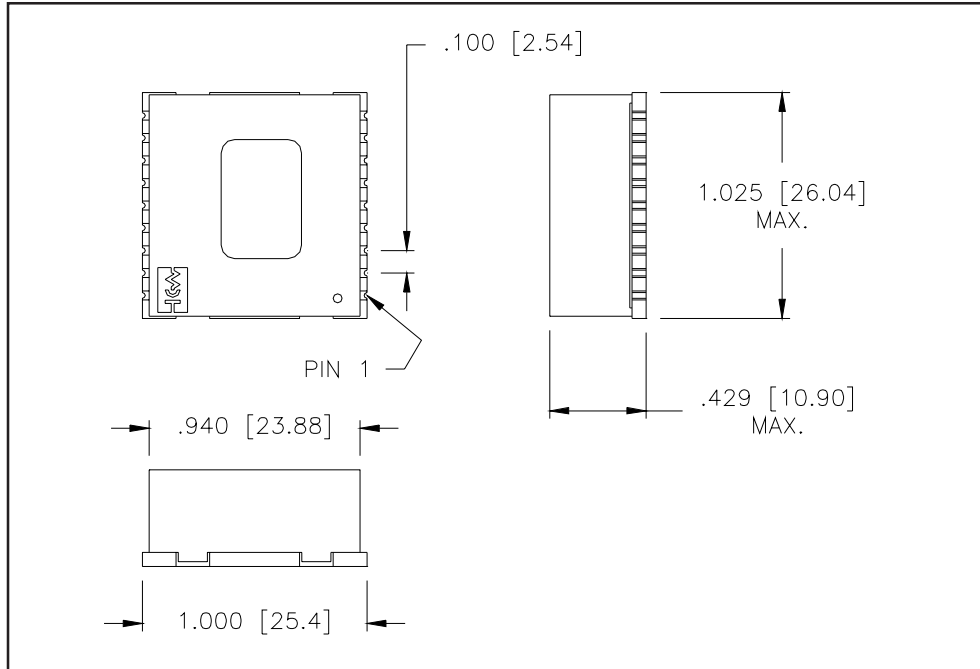

Recommended Footprint Dimensions

Figure 3

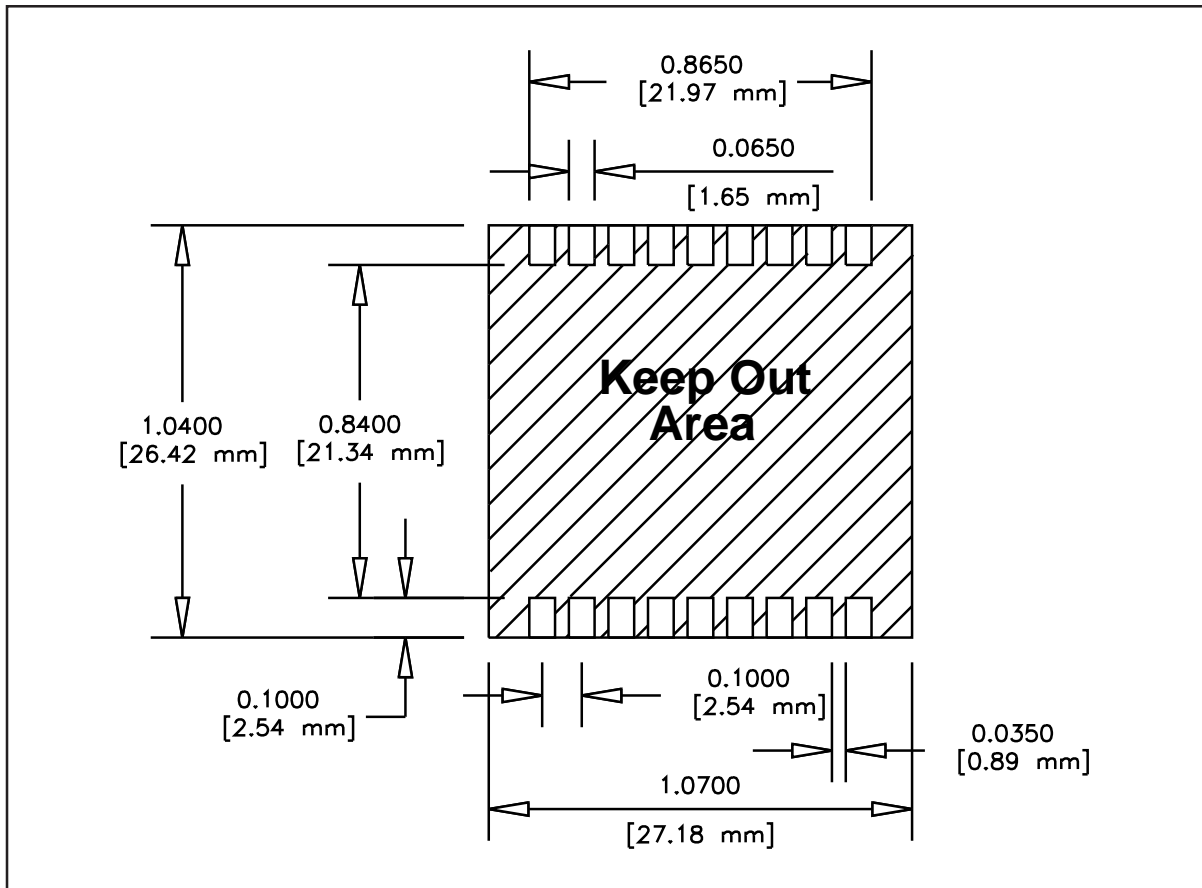

Tape and Reel Dimensions

Figure 4

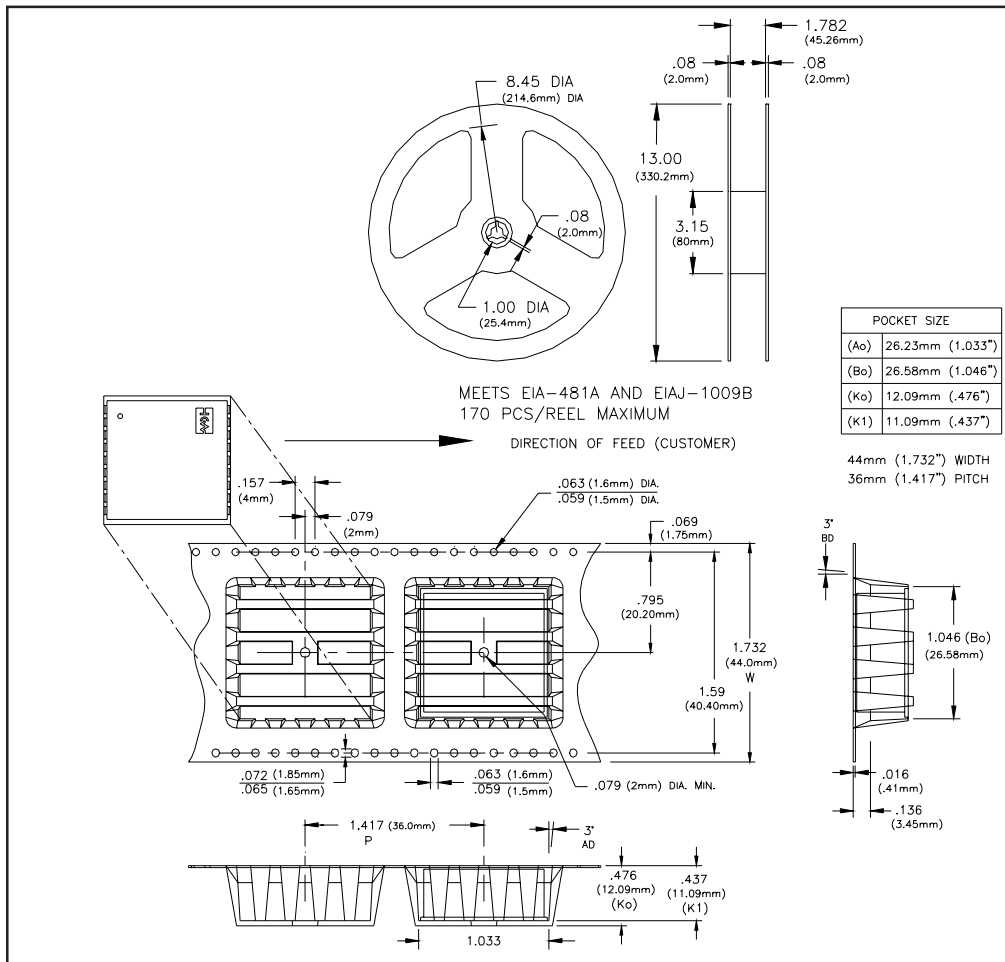

Solder Profile

Figure 5

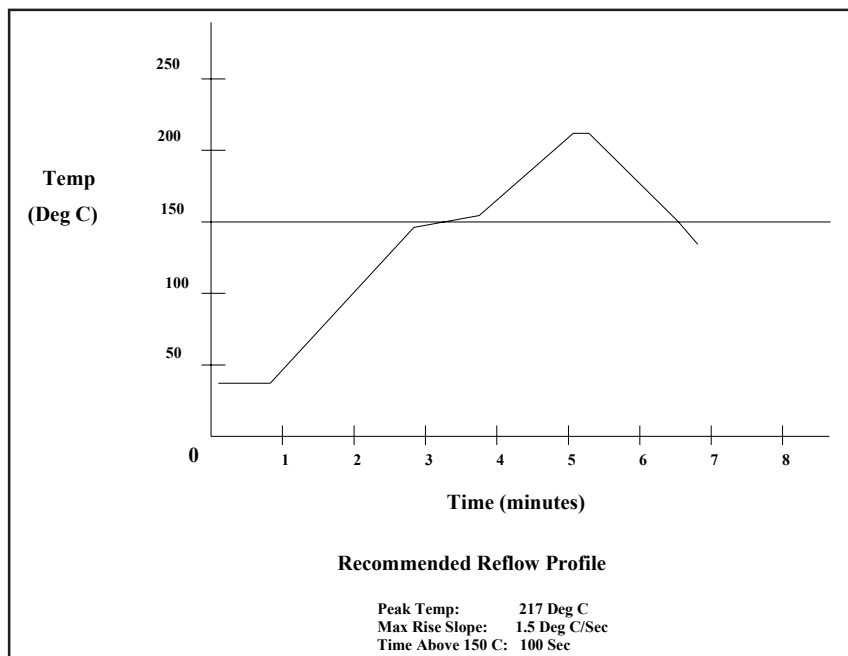

Typical Application

Figure 6

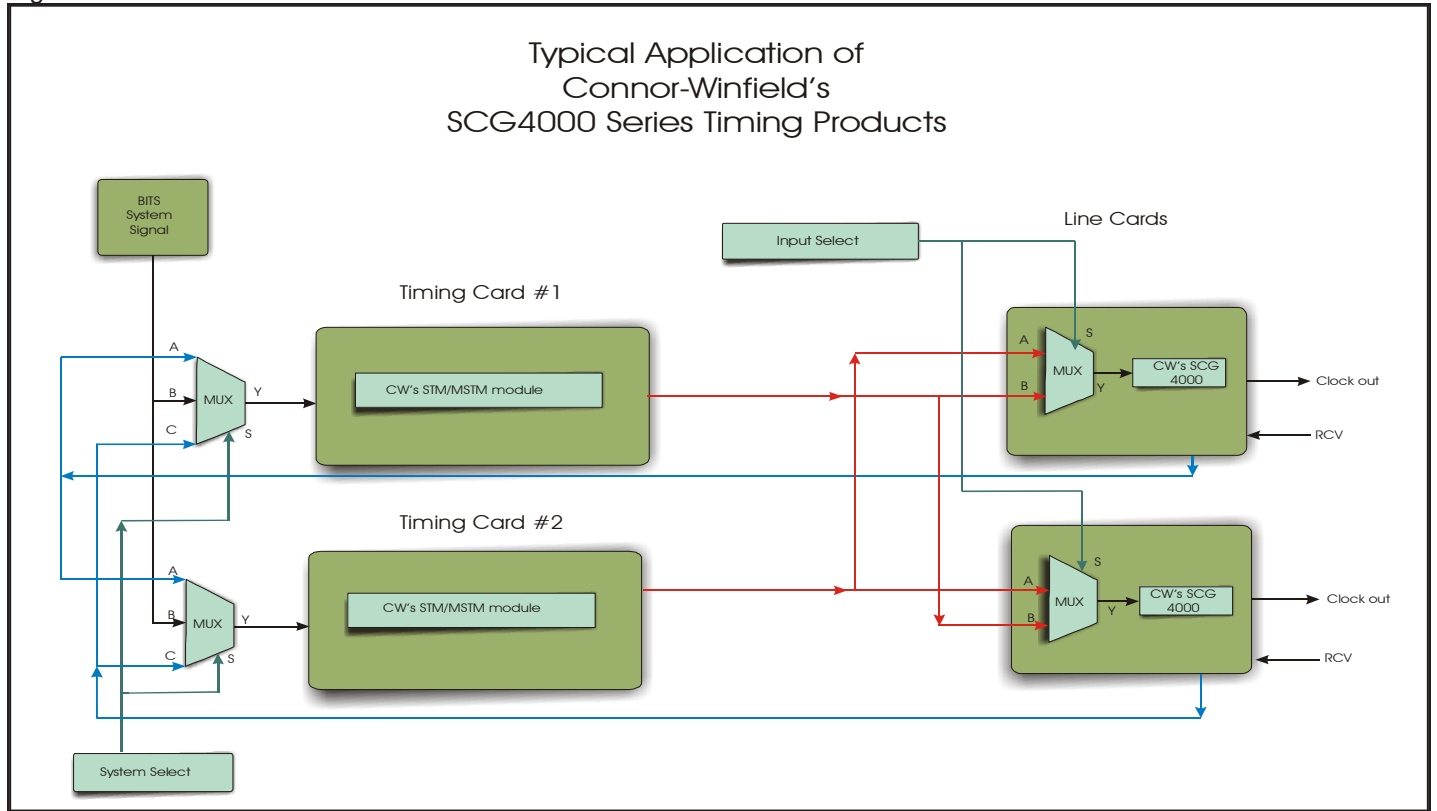

Typical System Test Set-up

Figure 7

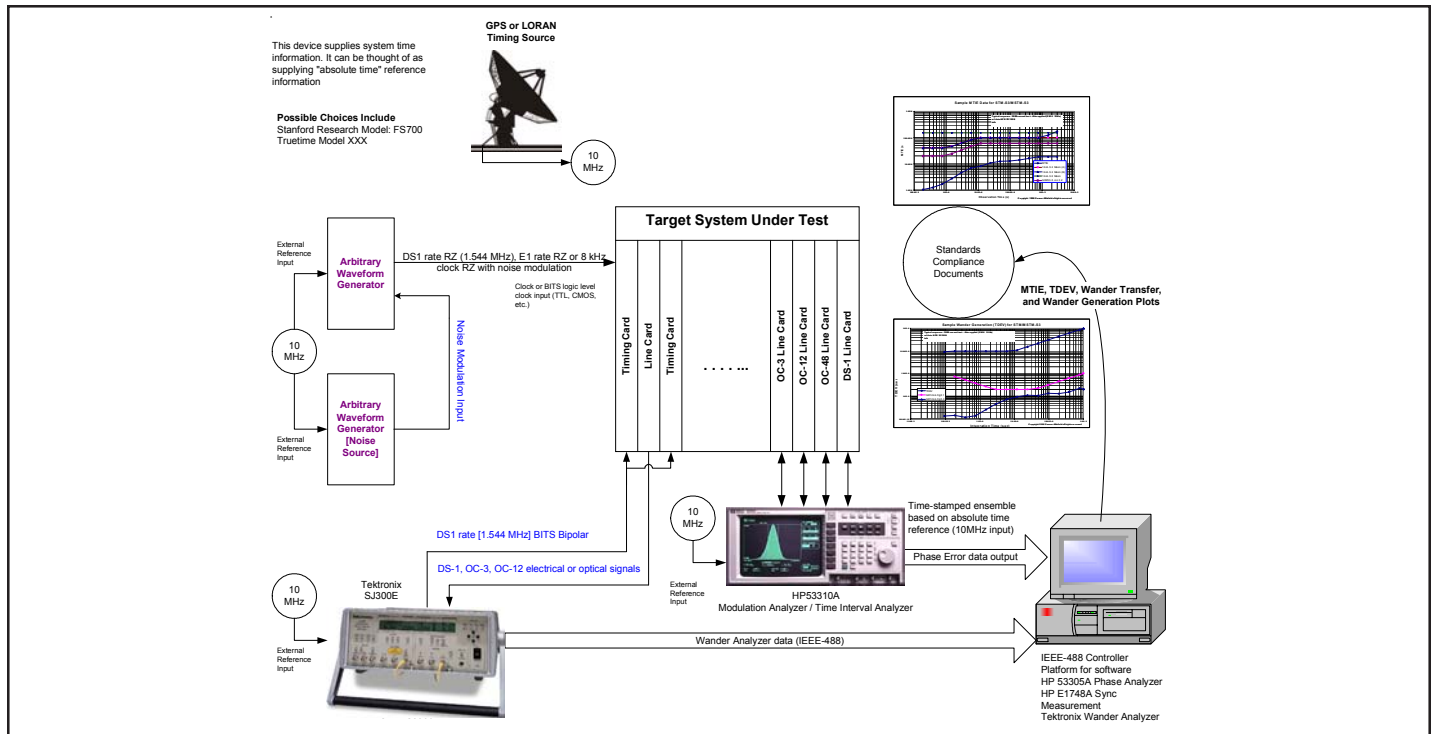

SCG4000 Series Typical MTIE

Figure 8

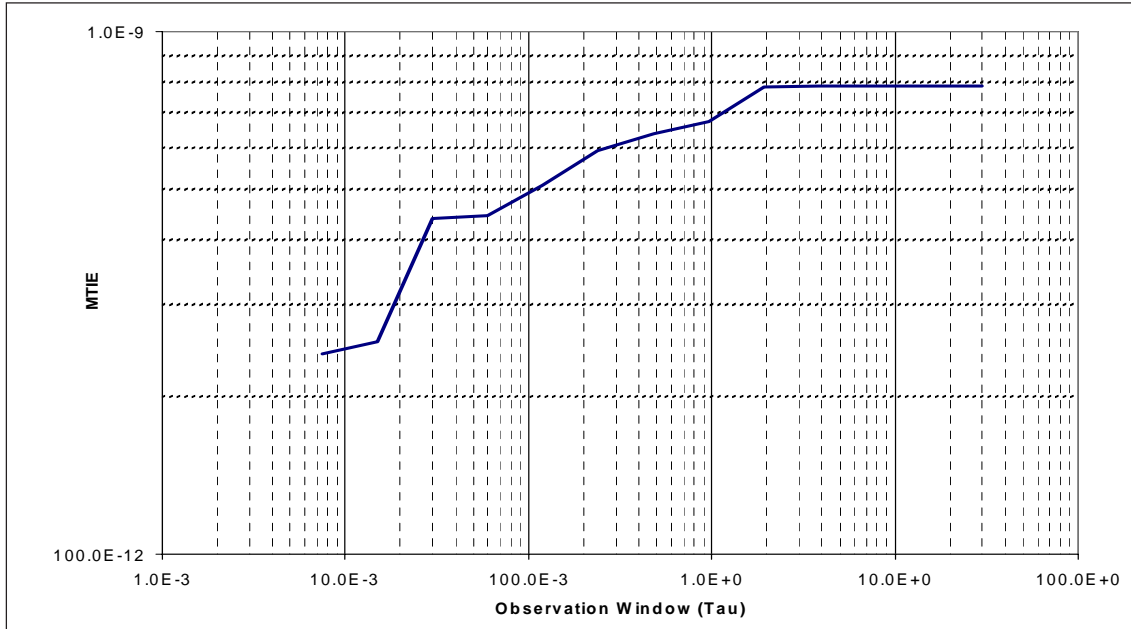

SCG4000 Series Typical TDEV

Figure 9

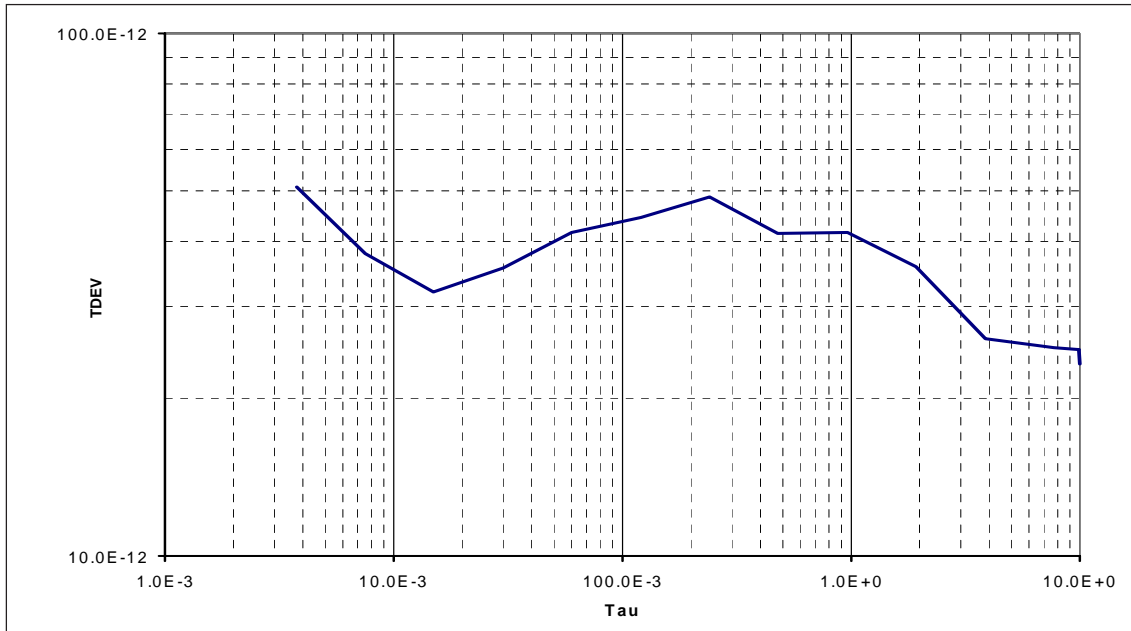



2111 Comprehensive Drive
Aurora, Illinois 60505
Phone: 630-851-4722
Fax: 630-851-5040
www.conwin.com

Revision	Revision Date	Note
P00	08/08/02	Preliminary Release
