

125 Series Wi125 GPS Receiver

2111 Comprehensive Drive
Aurora, Illinois 60505
Phone: 630-851-4722
Fax: 630-851-5040
www.conwin.com

P
R
O
D
U
C
T
B
R
I
E
F



Bulletin **SG163**
Revision **03**
Date **29 Nov 2011**

Description

The Wi125 is a small OEM surface mount GPS module specifically designed for use in synchronization and timing in WiMax applications. This compact module has an on-board programmable NCO oscillator that outputs a synthesized frequency up to 30 MHz that is steered by a GPS receiver. The self-survey mode of operation allows the receiver to enter a position hold mode allowing accurate timing to be continued with only one satellite being tracked.

Additionally, the 125 Series Wi125 has phase alignment of 1 PPS/10 MHz with a very stable holdover. The 1 PPS/10 MHz outputs maintain phase alignment with holdover being base only on the local oscillator, dismissing spurious GPS measurements during reacquisition. When the receiver regains GPS lock after a period of holdover, the 1PPS and 10 MHz outputs maintain phase alignment and are offset in frequency at the maximum rate of 100 ppb until the 1 PPS aligns with that of the GPS solution. This slow recovery from holdover allows for uninterrupted operation of the WiMax base station.

The Wi125 has a highly accurate output frequency, which can achieve full PRC MTIE performance. Additionally it can track satellites and provide GPS synchronization in weak signal areas including indoor applications, reducing the need for high antenna placement.

The Wi125 is RoHS compliant and an exceptionally small surface mount package with a highly integrated architecture that requires a minimum of external systems components allowing easy integration into host systems.

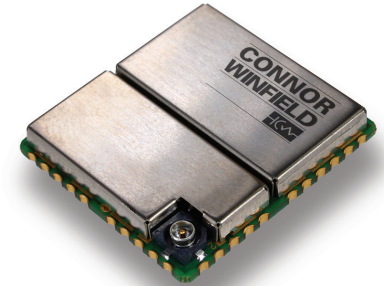

Features

- 1PPS/ 10 MHz Phase alignment
- Stable Holdover
- Holdover Recovery
- 1 PPS & NCO Frequency Output
- GPS/UTC time/scale synchronization to 25 ns RMS
- Stable proven design with long term availability and multi-year support
- 12 channel hardware correlator processor design
- OEM SM footprint 25 x 27 mm
- Automatic entry into holdover
- Loss-of-lock and entry-into-holdover indication
- RoHS Compliant ✓ RoHS

Block Diagram

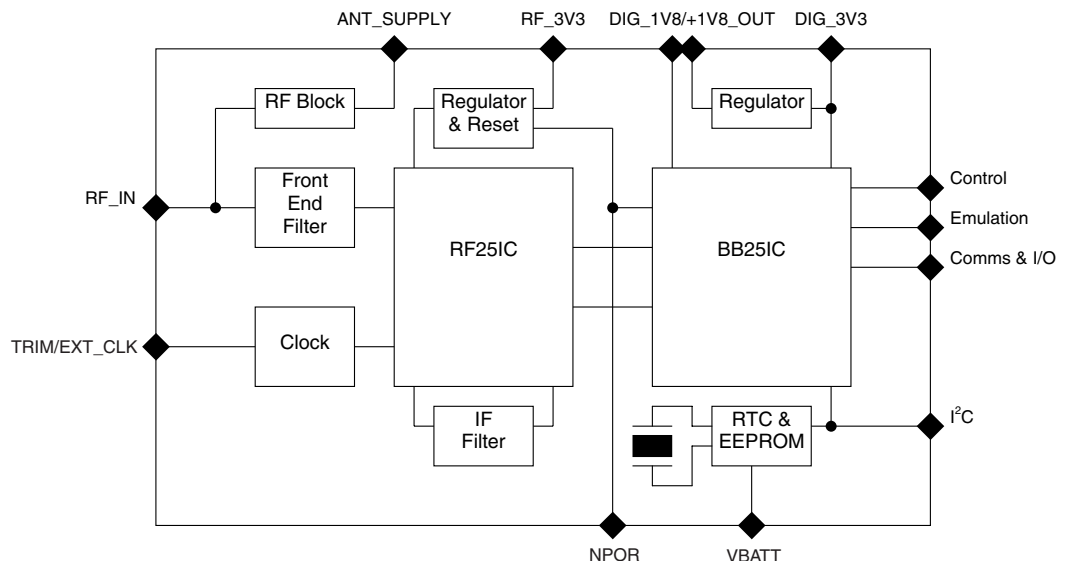

125 Series Wi125 GPS RECEIVER SPECIFICATIONS ¹

SPECIFICATIONS ¹

Physical	Module dimensions	25mm (D) x 27mm (W) x 4.2mm (H)
	Supply voltages	3V3 (Digital I/O), 3V3 (RF), 1V8 (Core option), 3V (Standby Battery)
	Operating / Storage Temp	-30°C to +75°C / -30°C to +80°C ²
	Humidity	5% to 95% non-condensing
	Max Velocity / Altitude	515ms ⁻¹ / 18,000m
	Max Acceleration / Jerk	4g / 1gs ⁻¹ (sustained for less than 5 seconds)
Sensitivity	Acquisition w/network assist	-155dBm
	Tracking	-156dBm
	Acquisition Stand Alone	-143dBm
Acquisition Time	Hot Start with network assist	Outdoor: <2s Indoor (-148dBm): <5s
	Stand Alone (Outdoor)	Cold: <45s
		Warm: <38s
		Hot: <5s
	Re-acquisition: <0.5s (90% confidence)	
Accuracy	Position: Outdoor / Indoor	<5m rms / <50m rms
	Velocity	<0.05ms ⁻¹
	Latency	<200ms
	Raw Measurement Accuracy	Pseudorange <0.3m rms, Carrier phase <5mm rms
	Tracking	Code and carrier coherent
Power	1 fix per second	0.6W typically
	Coma Mode Current (RF3V3+DIG 3V3)	10mA
	Standby Current (VBATT)	1.5µA
Interfaces	Serial	3 UART ports, CMOS levels; USB v1.1
	Multi-function I/O	1PPS Frequency Output available on GPIO [0]
		Event Counter/Timer Input
		Up to 4 x GPIO (multi-function)
		2 x LED Status Drive
		I ² C, External Clock (on special build)
	Protocols	Network Assist, NMEA 0183, Proprietary ASCII and binary message formats
	1pps Timing Output	25nS rms accuracy, <5nS resolution User selectable pulse width
	Event Input	30nS rms accuracy, <10nS resolution
	Frequency Output (GPIO [0])	10 Hz to 30 MHz (125 Series Wi125)
Receiver Type	12 parallel channel x 32 taps up to 32 point FFT. Channels, taps and FFT can be switched off to minimize power or simulate simpler designs.	
General	Processor	ARM 966E-S on a 0.18µ process at up to 120 MHz.

Note: 1. The features listed above may require specific software builds and may not all be available in the initial release.

2. Please contact factory for other temperature options.

125 Series Wi125 GPS MTIE PERFORMANCE

The graph below demonstrates the MTIE performance of the 125 Series Wi125 output frequency relative to a Caesium atomic clock, with the 125 Series Wi125 operating with a clear view of the sky.

MTIE: Fo=10.00 MHz; Fs=1.000 Hz; 11/19/03 05:45:08 PM, 11/20/03 09:08:18 AM,
HP 53132A: Test 545; 10 MHz NCO: Samples: 55388; Gate: 1 s; Ref ch2: 10.00 MHz; TI/Time Data Only; TI 1>2

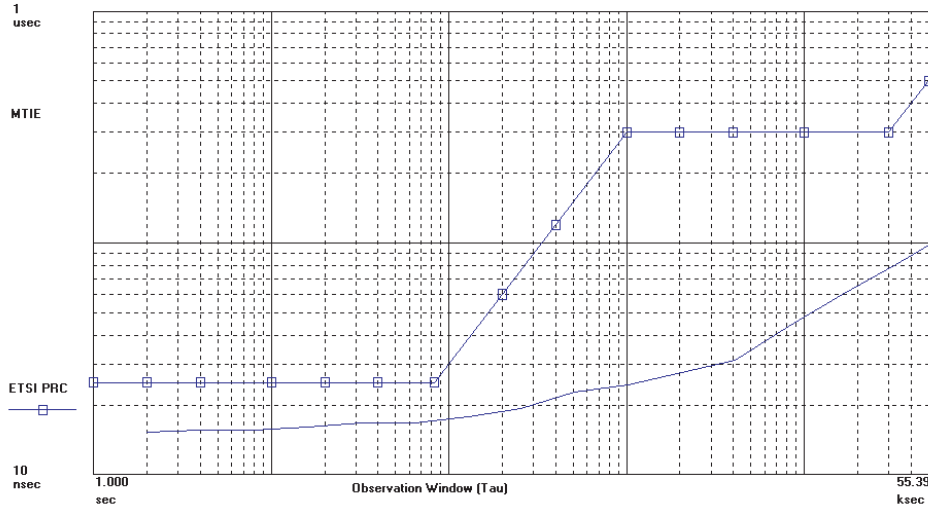

The graph below demonstrates the ability of the 125 Series Wi125 to continue to provide a GPS disciplined output frequency with the GPS aerial located completely inside a building (the degradation of MTIE performance is due to the effects of signal multi-path)

MTIE: Fo=10.00 MHz; Fs=999.0 MHz; 2/12/04 02:38:18 PM, 2/12/04 05:50:27 PM,
HP 53132A: Test 589; CW25_indoor_tim; Samples: 11506; Gate: 1 s; Ref ch2: 10.00 MHz; TI/Time Data Only; TI 1>2

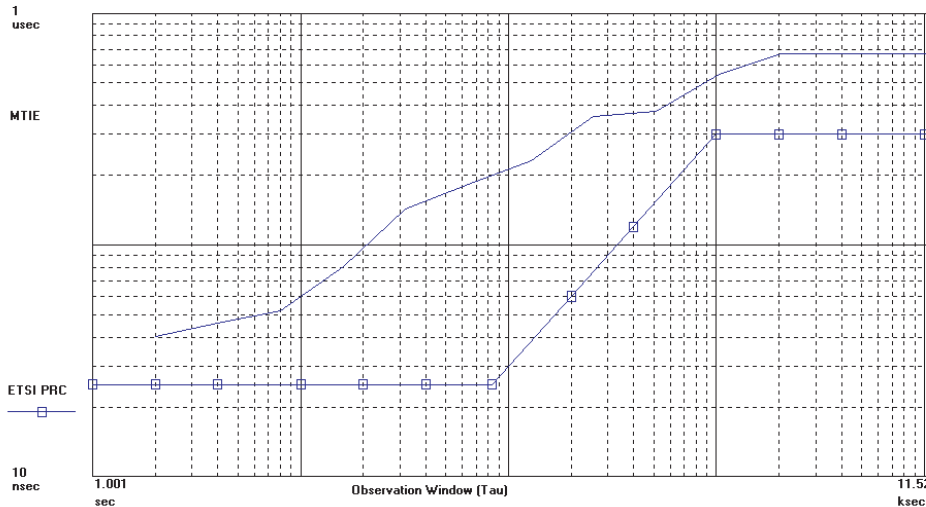

125 Series Wi125 GPS Receiver

Available at Digi-Key
www.digikey.com

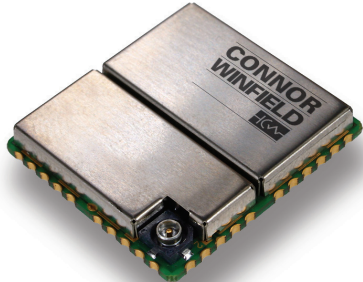

2111 Comprehensive Drive
Aurora, Illinois 60505
Phone: 630-851-4722
Fax: 630-851-5040
www.conwin.com
US Headquarters:
630-851-4722
European Headquarters:
+353-61-472221

Ordering Information

Wi125	-010.0M
	Output Frequency

Revision History

Revision	Revision Date	Note
00	04/13/10	Released
01	06/16/10	125 Series Updates and Revised to Release
02	10/20/11	Update to 1PPS (timing) Accuracy Specification
03	11/29/11	Updated to RoHS Compliant