

TFLD646

SURFACE MOUNT 9x14mm

3.3V LVCMOS TCXO

CONNOR WINFIELD



2111 Comprehensive Drive
Aurora, Illinois 60505
Phone: 630-851-4722
Fax: 630-851-5040
www.conwin.com

Description:

The Connor-Winfield TFLD646 is a Surface Mount Temperature Compensated Crystal Oscillator (TCXO). Operating at 3.3Vdc, the TFLD646 will maintain ± 4.6 ppm frequency tolerance over 20 years. The TFLD646 is offered in a surface mount package for automated assembly.

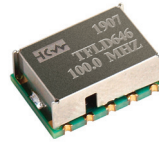

Features:

- 3.3V Operation
- Overall Frequency Tolerance: ± 4.6 ppm over 20 years.
- Temperature range: -40 to 85°C
- Low Jitter <1pS RMS
- Surface Mount Package
- Tape and Reel Packaging
- RoHS Compliant RoHS

Absolute Maximum Ratings

Parameter	Minimum	Nominal	Maximum	Units	Notes
Storage Temperature	-40	-	85	°C	
Supply Voltage (Vcc)	-0.6	-	6.0	Vdc	

Operating Specifications

Parameter	Minimum	Nominal	Maximum	Units	Notes
Frequency Range (Fo)	12.80	-	100.0	MHz	
Frequency Calibration @ 25°C	-1.5	-	1.5	ppm	
Frequency Tolerance	-4.6	-	4.6	ppm	1
Operating Temperature Range	-40	-	85	°C	
Supply Voltage (Vcc)	3.135	3.3	3.465	Vdc	
Supply Current (Icc)	-	9	12	mA	
Period Jitter	-	3	5	ps rms	
Phase Jitter (BW=12kHz to 20MHz)	-	0.5	1	ps rms	

Typical Phase Noise Characteristics

Parameter	Minimum	Nominal	Maximum	Units	Notes
Output Frequency (Fo)	12.80	77.76	100.0	MHz	
SSB Phase Noise at 10Hz offset	-65	-60	-55	dBc/Hz	
SSB Phase Noise at 100Hz offset	-95	-90	-85	dBc/Hz	
SSB Phase Noise at 1KHz offset	-125	-120	-120	dBc/Hz	
SSB Phase Noise at 10KHz offset	-140	-140	-140	dBc/Hz	
SSB Phase Noise at 100KHz offset	-145	-145	-145	dBc/Hz	

LVCMOS Output Characteristics

Parameter	Minimum	Nominal	Maximum	Units	Notes
LOAD	-	-	15	pF	
Voltage (High) (Voh)	90% Vcc	-	-	Vdc	
(Low) (Vol)	-	-	10% Vcc	Vdc	
Current (High) (Ioh)	-4	-	-	mA	
(Low) (Iol)	-	-	4	mA	
Duty Cycle at 50% of Vcc	45	50	55	%	
Rise / Fall Time 10% to 90%	-	3	5	ns	

Package Characteristics

Package Non-hermetic package consisting of an FR4 substrate with grounded metal cover.

Process Recommendations

Solder Reflow RoHS compliant. See solder profile page 2.
Wash Ultrasonic cleaning is not recommended.

Notes:

1) Inclusive of calibration, frequency vs. temperature stability, supply voltage change, load change, shock and vibration, 20 years aging.



Package Layout

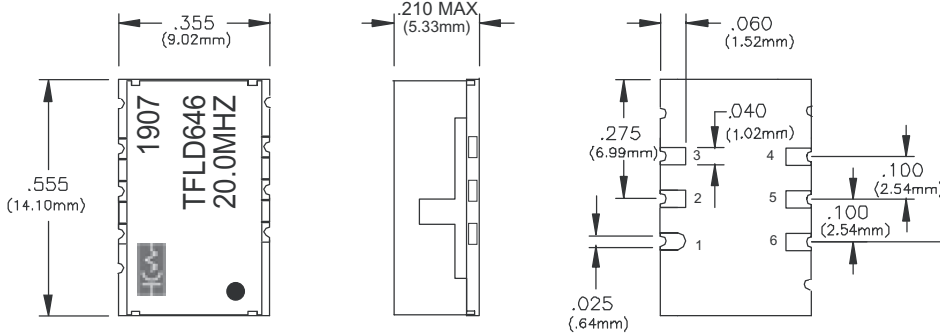

Dimensional Tolerance:
±.005 (.127mm)

Suggested Pad Layout

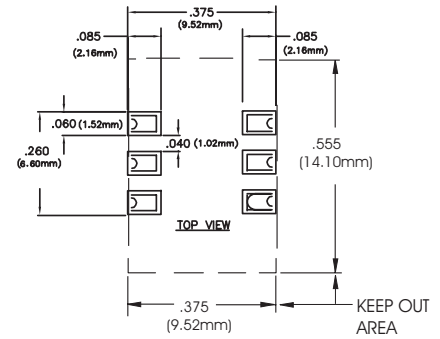

Output Waveform

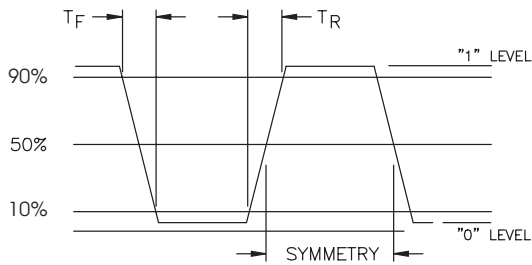

Test Circuit

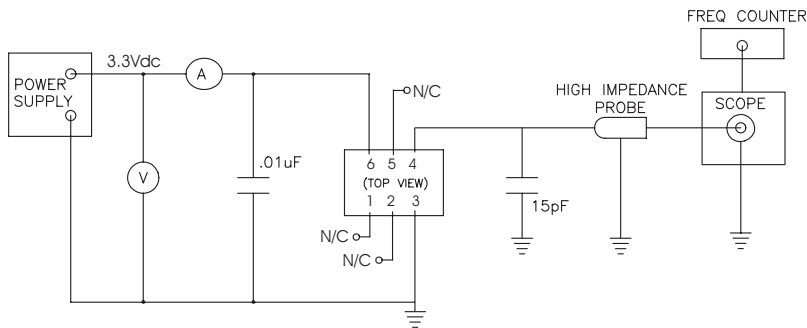

RoHS Solder Profile

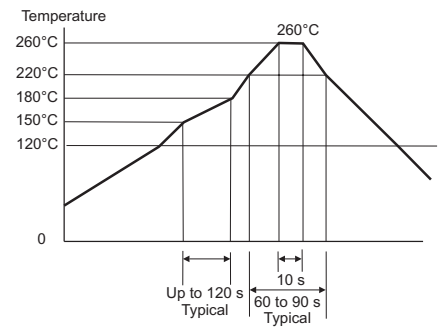

Tape and Reel Dimensions

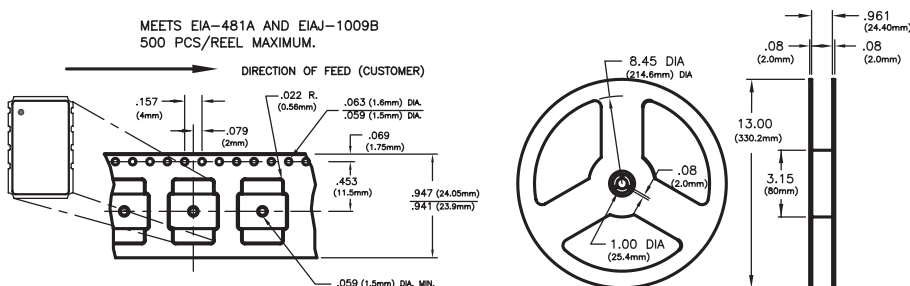

Ordering information:

TFLD646-020.0M
TFLD646-100.0M

Bulletin **TX138**
Page **2 of 2**
Revision **02**
Date **18 Feb 2019**