

CRYSTAL CONTROLLED OSCILLATORS

3.3V SURFACE MOUNT PECL OSCILLATOR

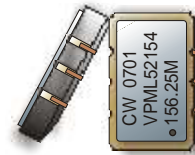

VPML52154

ABSOLUTE MAXIMUM RATINGS

TABLE 1.0

PARAMETER	UNITS	MINIMUM	NOMINAL	MAXIMUM	UNITS	NOTE
Storage Temperature		-40	-	85	°C	
Supply Voltage	(Vcc)	-0.5	-	7.0	Vdc	
Control Voltage	(Vc)	-0.5	-	7.0	Vdc	

OPERATING SPECIFICATIONS

TABLE 2.0

PARAMETER		MINIMUM	NOMINAL	MAXIMUM	UNITS	NOTE
Center Frequency	(Fo)	16.384	-	170	MHz	
Frequency vs. Temperature		-50	-	50	ppm	1
Operating Temperature Range		0	-	70	°C	
Supply Voltage	(Vcc)	3.135	3.3	3.465	Vdc	
Supply Current	(Icc)	-	-	60	mA	
Jitter (BW=10Hz to 20MHz)		-	-	5	ps rms	
Jitter (BW=12kHz to 20MHz)		-	-	1	ps rms	
SSB Phase Noise at 10Hz offset		-	-60	-	dBc/Hz	
SSB Phase Noise at 100Hz offset		-	-100	-	dBc/Hz	
SSB Phase Noise at 1KHz offset		-	-110	-	dBc/Hz	
SSB Phase Noise at 10KHz offset		-	-130	-	dBc/Hz	
SSB Phase Noise at 100KHz offset		-	-135	-	dBc/Hz	

INPUT CHARACTERISTICS

TABLE 3.0

PARAMETER		MINIMUM	NOMINAL	MAXIMUM	UNITS	NOTE
Control Voltage Range	(Vc)	0.3	1.65	3.0	Vdc	
Absolute Pull Range (APR)		+/-50	-	-	ppm	2
Monotonic Linearity		-10	-	10	%	
Input Impedance		-	50K	-	Ohm	
Modulation Bandwidth (3dB)		10	-	-	KHz	
Enable Input Voltage (Low)	(Vil)	-	-	1.68	Vdc	3
Disable Input Voltage (High)	(Vih)	2.275	-	-	Vdc	3

PECL OUTPUT CHARACTERISTICS

TABLE 4.0

PARAMETER		MINIMUM	NOMINAL	MAXIMUM	UNITS	NOTE
LOAD		-	-	50	Ohms	4
Voltage (High)	(Voh)	2.275	-	-	Vdc	
(Low)	(Vol)	-	-	1.68	Vdc	
Duty Cycle at 50% Level		45	50	55	%	
Rise / Fall Time 20% to 80%		-	-	1.0	nS	

PACKAGE CHARACTERISTICS

Package	Hermetically sealed "J" leaded ceramic surface mount package.
---------	---

Notes

- Referenced to Frequency measured at T=25°C with Control Voltage @ 1.65V.
- Absolute pull range (APR) is the minimum guaranteed pull range of the VCXO under all conditions over lifetime operation including deviation over temperature, supply and load variations, shock, vibration and aging. The APR is referenced to Fo. Positive Slope.
- When oscillator is disabled the true output is in a low state (Vol) and the complementary output is in the high state (Voh)
- Output terminated into 50 ohms into Vcc - 2.0Vdc or Thevenin equivalent.

DESCRIPTION

The Connor-Winfield VPML52154 is a surface mount 3.3V voltage controlled crystal oscillator (VCXO) with Differential PECL outputs. Based on a fundamental design, the VPML52154 is designed for phased lock loop applications requiring low jitter and tight stability.

FEATURES

- 3.3V OPERATION
- LOW JITTER <1ps RMS
- FREQUENCY STABILITY: ±50ppm
- TEMPERATURE RANGE: 0 to 70°C
- ENABLE/DISABLE FUNCTION
- DIFFERENTIAL PECL OUTPUTS
- J LEADED SURFACE MOUNT PACKAGE
- TAPE AND REEL PACKAGING

ORDERING INFORMATION

VPML52154 - 156.25 MHz

VCXO
SERIES

CENTER
FREQUENCY

Specifications subject to change without notice.

CRYSTAL CONTROLLED OSCILLATORS

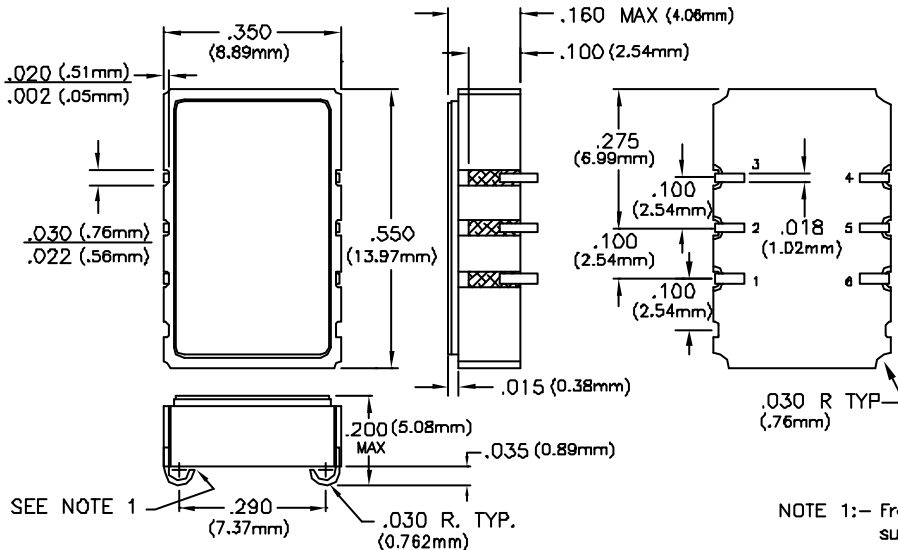

PIN	CONNECTION
1	CONTROL VOLTAGE
2	ENABLE/DISABLE
3	GROUND
4	Q OUTPUT
5	\bar{Q} OUTPUT
6	Vcc

NOTE 1:- Free end of J lead not attached to bottom surface.

OUTPUT WAVEFORM

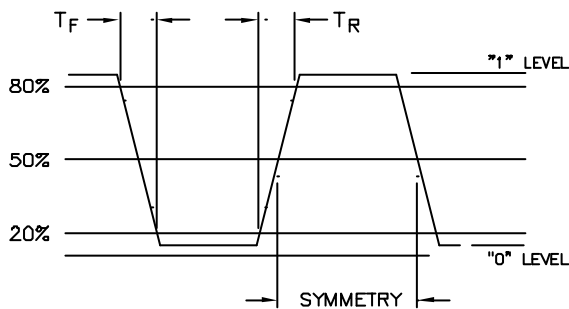

SUGGESTED PAD LAYOUT

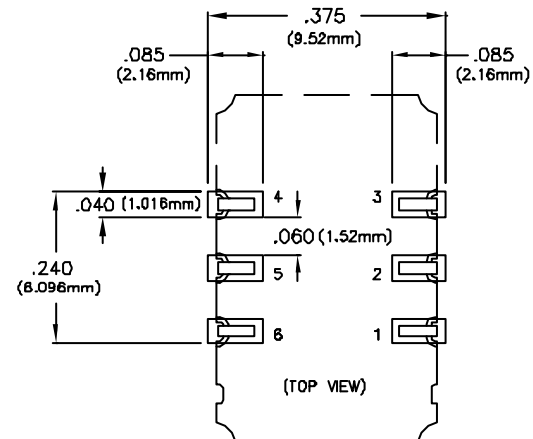

TEST CIRCUIT

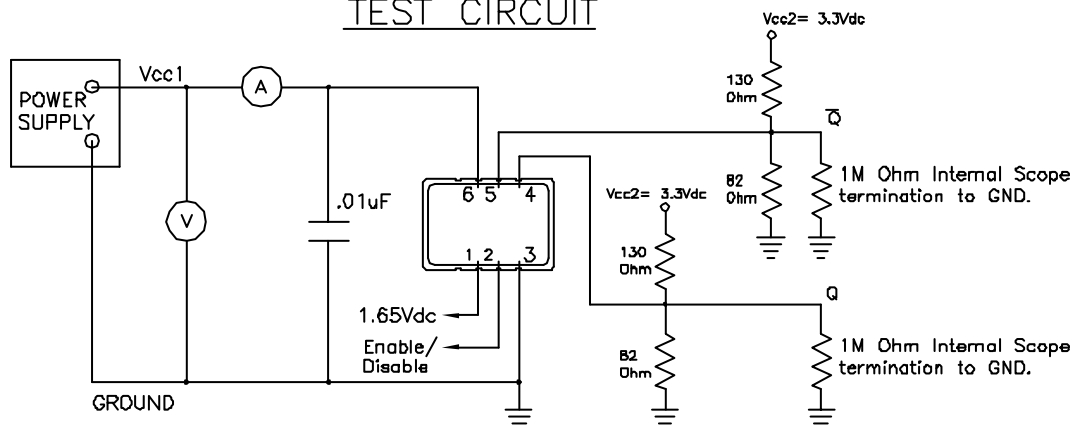

Specifications subject to change without notice.